



(Round 5 of the 2011 Speed FMSCI Indian National Rally Championship)

18th to 21st November 2011

Supplementary Regulations

Organizers : The Motor Sports Club Of Chikmagalur
Address : 971, Everest building, K.M.Road, Chikmagalur. 577101
Phone : 08262230770
Fax : 08262231381
email : mandalbobs@hotmail.com
Website : www.msccrallying.com

Rally HQ : ABC Trading corporation
Address : K.M.Road, Chikmagalur.
Phone : 08262235214/234959/231385
Fax : 08262231381
email : mandalbobs@hotmail.com



INDEX

Art	Description	Page No
1	Introduction	3
2	Organization	4
3	Programme	10
4	Entries	15
5	Insurance	19
6	Advertising & Identification	20
7	Tires	21
8	Fuel	21
9	Reconnaissance	21
10	Administrative Checks	22
11	Scrutineering, Sealing & Marking	23
12	Other Procedures	25
13	Identification of Officials	27
14	Prizes	27
15	Final Checks	29
16	Appendix 1 – Itinerary	31
17	Appendix 2 – Reconnaissance Schedule	35
18	Appendix 3 – CROs	36
19	Appendix 4 –Penalties	37
20	Appendix 5 - Compulsory and Option Advt.	39



1. Introduction

- 1.1 The **Error! Reference source not found.** is a 5th round of 2011 SPEED FMSCI Indian National Rally Championship (INRC) and will run in compliance with the International Sporting Code of the Federation Internationale de l' Automobile (FIA), its appendices, the 2011 General Prescription for Rallies (GP) of The Federation of Motor Sports Clubs of India (FMSCI), the relevant regulations concerning INRC or Cup, bulletins issued by the FMSCI and these Supplementary Regulations.

The FMSCI is the National Sporting Authority (ASN) of FIA in India.

Modifications, amendments and / or changes to these Supplementary Regulations will be announced as per Art.10.2 of the FMSCI GP.

- 1.2 **Road Surface** : All special stages are Dirt/ Gravel

1.3 **Distance of the Rally:**

Liaison	:	363.35 kms
Special Stage (SS)	:	104.30 kms
Total	:	467.65 kms



2. Organisation**2.1 FMSCI Titles for which the Rally Counts****Overall Champion Team**

FMSCI Indian National Rally Championship for Team 2011

Overall Champion Driver

FMSCI Indian National Rally Champion for Driver 2011

Overall Champion Co-Driver

FMSCI Indian National Rally Champion for Co-Driver 2011

2000 cc Champion Driver- N

FMSCI Indian National Rally Champion for Driver 2011- 1601-2000 cc

2000 cc Champion Co-Driver- N

FMSCI Indian National Rally Champion for Co-Driver 2011- 1601-2000 cc

1600 cc Champion Driver- N

FMSCI Indian National Rally Champion for Driver 2011- up to 1600 cc

1600 cc Champion Co-Driver- N

FMSCI Indian National Rally Champion for Co-Driver 2011 upto 1600 cc



1400 Star Cup Winner Driver

FMSCI 1400 Star Cup Driver 2011

1400 Star Cup Winner Co-Driver

FMSCI 1400 Star Cup Co-Driver 2011

Gypsy Cup Overall Winner Driver

FMSCI Gypsy Cup Overall Driver 2011

Gypsy Cup Overall Winner Co-Driver

FMSCI Gypsy Cup Overall Co-Driver 2011

Gypsy Cup Group N & T2 Winner – Driver

FMSCI Gypsy Cup Group N & T2 Driver 2011

Gypsy Cup Group N & T2 Winner – Co Driver

FMSCI Gypsy Cup Group N & T2 Co Driver 2011

2.2 FMSCI Permit Number/s

TBA



2.3 Organiser's name, address and contact details

Organizers : Motor Sports Club of Chikmaglur
 Address : 971, Everest building, K.M.Road, Chikmaglur. 577101
 Phone : 08262230770
 Fax : 08262231381
 email : mandalbobs@hotmail.com
 Website : www.msccrallying.com

Name of the National Sporting Authority:

The Federation of Motor Sports Clubs of India (FMSCI)
 A25, Krishna Towers, VI Floor,
 50 Sardar Patel Road,
 Chennai – 600 113
 Ph: (91) (44) 22352673 / 22355304 / 64506665

2.4 Organization Committee

Mr.T.N.Channabasve Gowda	President
Mr. K. Farooq Ahmed	Vice President
Mr.M.G.Babushankar	Secretary
Mr.Jowhar Azad	Joint Secretary
Mr. Chandramohan .S.A	Treasurer
Mr. I.T. Machiah	Member
Mr. Abhijeet Pai	Member
Mr. Divin .J.E.	Member
Mr .Vikram Sargod	Member



Management Committee

Mr.Rangaswamy,Deputy Commisioner	Mr.Vikas Kumar Vikas,SP
Mr. V.G. Siddhartha	Mr.T.N.Channabasve Gowda
Dr. Vishwanath, M.L.A, Kadur	Mr. C.T.Ravi, M.L.A, Chikmagalur
Mr. S.L. Bhoje Gowda	Mr. K.B.Mallikarjuna
Mr. Jowhar Azad	Mr. Vejay Anand
Mr. K.Farooq Ahmed	Mr. D Ramkumar
Mr. Babu Shankar	Mrs. Poornima Jairaj
Mr.T.C.Mallikarjuna	Mr.Jayanth Pai
Mr.S.V.Subramani	Mr.Javed Parveez
Mr.Naniah	Mr.Kiriti
Mr.Sudhindra Hebbar	Mr.Dilip Jain
Mr.Nisar Pasha	Mr.Jeetu Chabria
Mr. I.T. Machiah	Mr. Kashi Prasad S.R.
Mr. Abhijeet Pai	Mr. Abhilash.M.B.

2.5 FMSCI Stewards of the Meeting

Chairman of Panel of Stewards	: TBA
Steward	: Mr.Praneeth Perumal
Steward	: Mr.J. Prithiviraj

2.6 FMSCI Delegates & Observer

Technical Delegate	: TBA
Observer	: Mr.Shivu Shivappa

2.7 Senior Officials

Clerk of the Course	: Mr.D.Ramkumar
Addl. Clerk of the Course	: Mr. K.Farooq Ahmed



Deputy Clerk of the Course	: Mr.Jowhar Azad : Mr. Abhijeet Pai
Secretary of the Meet	: Mr. Balakrishna
Secretary to the Stewards	: Mr.Shajan Daniel
Competitor Relations Officer	: Ms.Sheeren Balachandran
Scrutineer	: Mr.Nisar Pasha
Assistant Scrutineers	: Mr. Ashad Pasha : Mr. Ravi
Chief Safety Officer	: Mr.I.T.Machaiah
Chief Medical Officer	: Dr. Sunil Kumar
Media Relations Officer	: Mr. David : Mr. Rudresh G.
Communication Chief	: Mr. Satya Pal
Stage Commanders	: Mr. Adahi Anthony (Birur Stage) : Mr.Gautham Reddy (University) : Mr. UMA SHANKER (SSS)
Stage safety officers	: Mr. Sudindra Hebbar (Birur stage) : Mr. LAN Mathew (University)
Chief Time Keeper	: Mr. Khader
Route coordinator	: Mr. Divin.J.E.



Start, finish ceremony
Coordinator : Mr. Babu Shankar.M.G.

Results Coordinator : Mr.Rajkumar

Service Park In charge : Mr.T.N.Channabasve Gowda

2.8 Rally HQ Location and Contact Details

From the Publication of these Supplementary Regulations till 18.00 hrs on 16th November 2011

Organizers : Motor Sports Club of Chikmagalur
Address : 971, Everest building, K.M.Road, Chikmagalur. 577101
Phone : 08262230770
Fax : 08262231381
email : mandalbobs@hotmail.com
Website : www.msccrallying.com

From : Friday 18th November 2011 to Monday 21st November 2011

Rally HQ : The Serai resort
Address : K.M.Road ,Chikmagalur.577101
Phone : 08262-224903 / 04 / 05 / 06
Fax : 08262 – 224915
email : Chikmagalur@theserai.in



Website : www.msccrallying.com

3. Programme

Opening Date for Entries

"With the Publication of these Regulations"

Venue: The Motor Sports Club of Chikmaglur, 971 Everest Building,
K.M.Road, Chikmaglur.577101

Closing date for entries

Monday, 7th November 2011

Time: 1800 hrs

Venue: MSCC office Chikmaglur

Closing date for Co-driver details

Wednesday 9th November 2011

Time: 1800 hrs

Venue: MSCC office Chikmaglur

Publication of Entry List

Wednesday, 16th November 2011

Time: 2000 hrs

Venue: MSCC office Chikmaglur



Issuing of the road book, map & service plan and registration for Reconnaissance

Thursday, 17th November, 2011

Time: 1200 hrs – 2000 hrs

Venue: ABC, Chikmaglur

Reconnaissance starts

Thursday, 17th November 2011

Time: 0800 hrs

Venue: Car no 1-23: Start of Birur stage

Car no 23 onwards: Start of Kuvempu university stage

Reconnaissance ends

Thursday, 17th November 2011

Time: 1400 hrs

Venue: Service Park @ Govt. Junior College, B.H. Road, Birur

Doctors briefing

Thursday, 17th November 2011

Time: 1900 hrs

Venue: The Serai Resort, K.M Road, Chikmaglur

Administrative Checks

Wednesday, 16th November 2011

Time: 1400 hrs – 2000 hrs

Venue: ABC Trading Co.



Pre-Event Scrutineering: Marking and sealing

Thursday, 17th November 2011

Time: 0930 hrs – 1430 hrs

Venue: ABC Trading Co.

Opening of media center and Media Accreditation

Thursday, 17th November 2011

Time: 1100 hrs

Venue: The Serai Resort, K.M Road, Chikmaglur

Reconnaissance of SSS

Friday, 18th November 2011

Time: 1030 hrs – 1130 hrs

Venue: Amber Valley Residential School

Note: Walking reccee.

Compulsory Drivers briefing

Friday, 18th November 2011

Time: 1130 hrs

Venue: The Serai Resort, K.M Road, Chikmaglur

Pre rally press conference

Friday, 18th November 2011

Time: 1200 hrs

Venue: The Serai Resort, K.M Road, Chikmaglur



Ceremonial start

Time: NA

Venue: NA

Shakedown

NA

1st Stewards Meeting

Thursday, 17th November 2011

Time: 2000 hrs

Venue: The Serai Resort, K.M Road, Chikmaglur

Publication of list of crews authorized to start for Day 1Friday, 17th November 2011 Time: 2100 hrs

Venue: The Serai Resort K.M Road, Chikmaglur and ABC trading Co. K.M Road, Chikmaglur

Publication of start list for day 2Saturday, 19th November 2011

Time: 2100 hrs

Venue: The Serai Resort K.M Road, Chikmaglur & ABC trading Co. K.M Road, Chikmaglur



Location of Start & Finish of various legs		
Day 1 Sec 1	Start:Friday,18 th November 2011,1330 hrs Finish:Friday,18 th November 2011,1428hrs	Start and Finish at ABC Trading Co.
Day 1 Sec 2	Start:Saturday,19 th November 2011, 0830 hrs Finish:Saturday,19 th November 2011,1740 hrs	Start and Finish at ABC Trading Co.
Day 2	Start: Sunday ,20 th November 2011,0602 hrs Finish: Sunday,20 th November 2011,1421 hrs	Start and Finish at ABC Trading Co.

Finish of the Rally

Sunday 20th November 2011

Time: 1421 hrs

Venue: ABC Trading Co.

Publication of Provisional Final Classification

Sunday 20th November 1830 hrs

Venue: ABC Trading Co. and The Serai resort

Champagne shower ceremony

Sunday 20th November 1600hrs



Venue: ABC Trading Co.

Post-event Scrutineering

Sunday 20th November 2011

Time: 1630 hrs.

Venue: ABC Trading Co.

Prize Giving Ceremony

Time : 2030 hrs

Venue : ABC Trading Co.

Post-event Press Conference

Sunday 20th November 2011

Time: 1730 hrs

Venue: The Serai resort

4. Entries

4.1 Opening & Closing date for entries

Date of Opening of Entries: "With the Publication of these Regulations"

Date of Closing of Entries: Monday 7th November 2011 at 1800 hrs



4.2 Entry Procedure

Those wishing to take part in the Coffee Day Rally 2011 must send the enclosed entry form, duly completed, to the organizers at the address given in Art.2.3 prior to the closing of entries. If this application is sent by fax or e-mail, the original must reach the organizers within 2 days following the close of entries.

4.3 Number of entrants accepted and classes

The maximum number of entries shall be 50 cars. If more than 50 entries are received the organizers reserve the right to decide which entries will be accepted.

Entries will be grouped into:

Production cars (Group N+)

Cylinder Capacity Classes:

- From 1601 cc up to & including 2000 cc

Production cars (Group N)

Cylinder Capacity Classes:

- From 1601 cc up to & including 2000 cc
- Upto & including 1600 cc

1400 Star Cup

Cars as per regulations of 2011 FMSCI 1400 Star Cup



Gypsy Cup

1000 cc and 1300 cc T1

1000 cc and 1300 cc T2 & Group N

Open Class Cup

Cars as per regulations of 2011 FMSCI Open Class Cup

4.4 Entry Fees

Sl. No	Class	Maximum entry Fee With Optional Advertising	Maximum Entry Fee Without Optional Advertising
1.	National Championship Classes		
I	When entrant & Driver are same	Rs. 15,000/-	Rs. 30,000/-
II	When Entrant is a Team	Rs. 35,000/-	Rs. 45,000/-
	First Time Privateer	Less 30%	Less 30%
2.	Support Classes		
A	1400 Star Cup	Rs. 12,500/-	Rs. 17,500/-
	When Entrant is a Team	Rs. 15,000/-	Rs. 30,000/-
B	Gypsy Cup	Rs. 7,500/-	Rs. 12,500/-
C	Open Class Cup	Rs. 10,000/-	Rs. 15,000/-



First Time Privateer: Those who have not entered a round of the INRC or Rally Star Cup in any previous year are entitled for a discount of 30% of the entry fee for all rounds of the 2011.

The Entry Fee includes:

Item	Number
Service Vehicle Plates	2
Supplementary Regulations	1
Road Book/s	1
Safety Plan	1
Service Manual	1
Route Map	1
Team Passes	6
Guest Passes for SSS	2
Service Park area	20 Sqm
Service park Cafeteria entry passes for Day 1 & 2	2

4.5 Payment details

The entry fees can be paid either by ECS or Demand Draft in favour of **Motor Sports Club of Chikmaglur** payable at **Chikmaglur** OR in cash.

Bank : Bank of India
 BranchCode : BKID
 IFSC Code : BKID0008443
 Account No. : 844310100000241



4.6 Refund of Entry Fees

Entry fees will be refunded in full:

- To candidates whose entry has not been accepted.
- In the case of the rally not taking place.

The organizers may refund 50% of the entry fee to those competitors, who, for reasons of 'force majeure', duly accepted by the organizing committee, were unable to start the rally.

5. Insurance

5.1 Cover provided by FMSCI with Permit

The organizers holding a valid 2011 FMSCI Permit for an event are covered for :

Third Party Public Liability for Rs.50 lakhs valid during the running of the event.

A maximum of **100 officials** officiating and **150 competitors** with valid FMSCI Competition License participating in various events across the Country on a given day are covered for Personal Accident Insurance for Rs.2 lakhs with Rs.40,000/- medical expense extension per person.

5.2 Additional Insurance taken by the organizer

Public Liability: Insurance for Rs.50 lakhs which adequately covers any liability incurred during the running of the event for injury to third persons or damage to public property has been taken.



5.3 EXCLUSION OF COVER

The service vehicles and cars used for reconnaissance, even those bearing special plates issued by the organizers, are not covered by the insurance policy of the rally.

5.4 Compulsory Insurance for Competitors

ALL CREWS COMPETING IN THIS EVENT MUST HAVE A MINIMUM PERSONAL ACCIDENT HIGH RISK INSURANCE POLICY, COVERING MOTOR SPORTS, FOR RS.2 LAKHS (HIGH RISK TABLE 3 OR ABOVE).

5.5 Rally Cover Insurance for competing vehicles

All competing cars must have Rally Cover Insurance for the vehicle valid at least from the date of pre-event scrutineering till the end of rally (ie: From 18th to 20th of Nov 2011).

5.6 Accident Reporting

In the event of an accident on a Special Stage, the competitor or his representative must notify the next radio point. Any accident during transport / liaison section must be informed to the Clerk of the Course within 4 hours giving full details including names and addresses of those involved and any witnesses.

6. Advertising and Identification

Please refer Art.15 of FMSCI General Prescriptions for Rallies.

Optional Advertising is as per Appendix 5.



Competition numbers, Rally plates and advertising shall be affixed on the car before scrutineering. All crews must present their cars for fixing rally plates and optional advertising 60 minutes before their scheduled time slot of pre-event scrutineering. Space for the organizer's advertisement must be reserved on the car, unless higher entry fees as per Art.4.4 are paid.

7. Tyres

7.1 Tyres specified for use during the rally

As per Appendix IV of the FMSCI General Prescriptions of the Rallies.

8. Fuel

FREE as per Art.9.1 of the 2011FMSCI Technical Regulations for 4W.

9. Reconnaissance

9.1 Procedure for registration

Crews must report to Rally HQ for registration prior to commencing reconnaissance. They must submit details of the reconnaissance car.

Each crew will be issued with two vehicle identification cars which must be displayed on top of the co-driver's side of the front windscreen and on the co-driver's rear side window during reconnaissance.

9.2 Specific and / or National Restrictions

9.2.1 For all competitors, reconnaissance will be carried out in accordance with the 2011 FMSCI General Prescriptions with a



maximum of 2 passes over every stage in accordance with the reconnaissance schedule given in Appendix 2.

- 9.2.2** Reconnaissance will be conducted strictly in accordance with the published schedule. No late entry in to a stage for reconnaissance will be permitted.
- 9.2.3** Reconnaissance outside the schedule is considered a very serious offence and will be reported to the Stewards who may apply sanctions.
- 9.2.4** Maximum Speed allowed on all special stages during reconnaissance is 60 kmph
- 9.2.5** Crews must have the vehicle headlamps switched on while traveling on special stages during reconnaissance.
- 9.2.6** Crews are only permitted to enter a special stage from the start points shown in the road book and will NOT, under any circumstances drive in a direction opposite to that of the rally, unless instructed by an official of the event.
- 9.2.7** Crews must stop at the Start and Finish (and other locations where instructed) of the stage where rally official will endorse the crew's reconnaissance pass card.

10. Administrative Checks

Date : Wednesday 16th November 2011
Place : ABC Trading Co.,K.M.Road ,Chikmaglur
Time : 0900 hrs – 2200 hrs.

10.1 Documents to be presented:

- FMSCI Entrant Competitors License
- FMSCI Driver Competition License
- FMSCI Co-Driver Competition License



- Civil Driving License of the Driver
- Civil Driving License of the Co-Driver
- Vehicle Registration Papers
- Vehicle Insurance Papers
- Special Rally Cover Insurance for the vehicle as per Art.5.5 of SRs
- PERSONAL Accident Insurance Policy as per Art.5.4 of SRs
- Three recent identity photos (4 cm X 4 cm) of Driver
- Three recent identity photos (4 cm X 4 cm) of Co-Driver
- Details concerning Reconnaissance Vehicle
- Medical History Form
- A letter of authority from the owner of the vehicle for use of the vehicle in the rally if the vehicle is not in either of the crew's name
- Self attested photocopy of PAN card

COMPETITORS ARE REQUIRED TO HOLD ADMINISTRATIVE CLEARANCE PASS PRIOR TO PRE-EVENT SCRUTINEERING.

11. Scrutineering, Sealing & Marking

11.1 Scrutineering Venue and Time Table

Date : Thursday 17th November 2011

Place : ABC Trading Co.,K.M.Road, Chikmaglur.

Cars	Time	Cars	Time
50 - 46	08.00 - 08.45hrs	45 - 41	08.45 – 09.30hrs
40 - 36	09.30 – 10.15hrs	35 - 31	10.15 – 11.00hrs
30 - 26	11.00 – 11.45hrs	25 - 21	11.45 – 12.30hrs
Lunch	12.30 – 13.30hrs		
20 - 16	13.30 – 14.15hrs	15 - 11	14.15 – 15.00hrs
10 - 06	15.00 – 15.45hrs	05 - 01	15.45 – 16.30hrs



Competing crew may send their vehicle for pre-event scrutineering with their representative, who must carry an authorization letter from the crew member.

11.2 Mud Flaps

Mud Flaps must comply with Art.7.7 of the 2011 FMSCI Technical Regulations for 4 wheelers. Missing or ineffective mud flap will incur a penalty of Rs.1000/- per mud flap.

11.3 Windows

The windows must comply with Art.11 of the 2011 FMSCI Technical Regulations for 4 wheelers.

11.4 Driver's Safety Equipment

Competitors helmets (Art.13) and fire retardant suit (Art.14 of the 2011 FMSCI Technical Regulations for 4 wheelers) will be checked during the pre-event scrutineering.

11.5 Noise levels

Not applicable

11.6 Special National Requirements

Not applicable.

11.7 Installation of Safety Tracking System

Not applicable



12. Other Procedures

12.1 Ceremonial Start Procedure and Order

Date : Not Applicable

Place : Not Applicable

All crews, in their driving suits, must participate in the Ceremonial Start even if they are not able to participate in its competing Car, as per Art.39 of the FMSCI General Prescription for Rallies.

A pre start holding area, open from 11.30 hrs & 12.30 hrs on Friday 18th November 2011 will be organized. All competing cars must be parked in their allotted space, as guided by the marshals, before 12.30 hrs. Any car reporting outside this time frame will be penalized at the rate of Rs.500/- per minute up to maximum of 10 minutes before the scheduled start time. Competitor's cars reporting later than 10 minutes prior to their scheduled start time will not take part in the Ceremonial Start and the Competitor will be referred to the Stewards for further action.

The start interval at the Start Ramp will be as directed by the Event officials.

12.2 Finish Procedure

Rally will finish at TC 10D. Thereafter, crews must follow the instructions of the officials during the podium ceremony. From podium, selected cars are obliged to follow the route described in Informative Road Book to Final Scrutineering. Rest of the cars will



report to Finish Parc Ferme and remain there till Official Final Classification or instructions by Stewards of the Meet.

While the cars are between Podium Finish and Post Event Scrutineering, they are under Parc Ferme regulations and will be observed by the marshals.

12.3 Permitted early check-in

12.3.1 The Crews are permitted to check-in early at the following TCs without incurring any penalty.

TC 1D Day 1 Section 1

TC 5E Day 1 Section 2

TC 8A Regroup-in

TC 9C Finish of Rally

12.3.2 The time cards will be changed during the rally and will be issued at following controls

0, 1E, 3A, 3D, 5A, 5D, 5F, 7A, 7 D,8 B

12.4 Super Special Stage / Special Stage procedure and running order

12.4.1 Cars will start in reverse order in Super Special Stage-1 with time interval of 4 minutes between two cars on Friday 18th November 2011. On Sunday 20th Nov 2011 the SSS will run in forward order with time interval of 4 minutes.

12.4.2 A photocell will be placed 75 cm from the starting line and will be used to detect jump starts. Should the system fail, the start will be given as per Art.33.3 of FMSCI General Prescription for rallies.



12.5 Any special procedures / activities including organizers' promotional activities

NIL

12.6 Official time used during the rally

Official time to be used during the rally will be that of GPS time (GMT + 5.30 hrs). This will be given at the time of Driver's Briefing Meeting.

13. Identification of Officials

Post Chief	: Green Vest with Black "POST CHIEF"
Other Post Officials	: Green Vest with Black "CONTROL"
Medical Officers	: Yellow Vest
Safety Marshals	: White Vest with Red "SAFETY"
Spectator Control	: Orange Vest with Black "SPECTATOR CONTROL"
Competitor Relations Officers	: Red Vest with Black "C. R. O."
Stage Commander	: Dark Blue Vest with White "STAGE COMMANDER"
Scrutineers	: Light Blue Vest with Black "SCRUTINEER"
Radio Marshals	: Yellow Vest with Black "Radio Point Symbol"
	:
	:

14. Prizes (for Drivers & Co-Drivers)

14.1 Prizes will be distributed separately at 20.30 hrs on Sunday 20th November 2011 at ABC Trading Co.



National Championship Classes			
Pos	Overall	2000cc N	1600cc N
1 st	Rs.50,000/-Trophies	Rs.30,000/-+Trophies	Rs.30,000/-+Trophies
2 nd	Rs.30,000/-+Trophies	Rs.20,000/-+ Trophies	Rs. 20,000/- + Trophies
3 rd	Rs.20,000/-+ Trophies	Rs.10,000/-+ Trophies	Rs. 10,000/- + Trophies
4 th	Rs.10,000/-+ Trophies		
5 th	Trophies		

		Support Classes	
Pos	Overall Gypsy Cup	Gypsy Gr N & T2	Open Class Cup
1 st	Rs. 30,000/- + Trophies	Rs.15,000/- + Trophies	Rs. 30,000/- + Trophies
2 nd	Rs. 20,000/- + Trophies	Rs.10,000/- + Trophies	Rs. 20,000/- + Trophies
3 rd	Rs. 10,000/-+Trophies	Rs.5,000/- + Trophies	Rs. 10,000/- + Trophies

14.2 Support Class: 1400 Star Cup

Entries	> 16	13 - 16	9 -12	5 – 8	1 - 4
1st	Rs.30,000	Rs.30,000	Rs.30,000	Rs.30,000	Rs.30,000
2nd	Rs.27,500	Rs.27,500	Rs.27,500	Rs.27,500	-
3rd	Rs.25,000	Rs.25,000	Rs.25,000	-	-
4th	Rs.22,500	Rs.22,500	-	-	-
5th	Rs.20,000	-	-	-	-



All cash prize winners shall be presented with a trophy, the minimum of 3 trophies per category is to be presented.

All cash prize money is subject to TDS in force.

Best Tuner : Trophy to the Tuner of overall winner

15. Final Checks

15.1

Date : Sunday 20th November 2011

Place: ABC Trading Co.,K.M.Road , Chikmagalur.

Time : 1630 hrs

Representative of competitor's service team is to attend.

15.2 Protest Fees

The sum of protest fees set by the FMSCI is Rs.10,000/-

If the protest requires the dismantling and re-assembly of a clearly defined part of the car (engine, transmission, steering, braking system, electrical installation, body work, etc.) the protestor must lodge an additional deposit of Rs.6000/-.

The expenses incurred in the work and in the transport of the car shall be borne by the claimant if the protest is unfounded, or by the competitor against whom the protest is lodged if it is upheld.

If the protest is unfounded, and if the expenses incurred by the protest (scrutineering, transport, etc.) are higher than the amount of the



deposit, the difference shall be borne by the claimant. Conversely, if the expenses are less, the difference shall be returned.

15.3 Appeal Fees

The Appeal fee set by FMSCI is a sum of Rs.80,000/-

The amount of Rs.40,000/- is payable along with the intention to appeal and the balance Rs.40,000/- payable along with the grounds of appeal.

Approved by FMSCI



Appendix 1 Itinerary

Itinerary								
Day 1 Section 1 Friday 18 th November 2011								
TC/ SS	LOCATION	SS DIST	LIASON DIST	TOTAL DIST	TARGET TIME	FIRST CAR	AVG SPEED	
0	ABC start					13:30		SEC 1
1	Amber Valley SSS		3.40	3.40	00:15	13:45	13.60	
SS1	Amber valley SSS start	3.00			00:03	13:48		
1A/B	Regroup in/ Service in		3.30	6.30	00:18	14:06	21.00	
	FLEXI SERVICE 'A' (ABC)	(3.00)	(6.70)	(9.70)	00:20			
1C	Service 'A' out					14:26		
1D*	Parc Ferme in		0.05	0.05	00:05	14:31	0.60	
Day 1 Section 2 Saturday 19 th November 2011								
1E	ABC Start					08:00		SEC 2
1F	Service In		63.00	63.00	01:20	09:20	47.25	
	Service 'B' Birur		(63.00)	(63.00)	00:20			
1G	Service out					09:40		
2	Kuvempu University		16.50	16.50	00:30	10:10	33.00	



SS2	Kuvempu 1 Start	17.50			00:03	10:13		
3	Birur		24.28	41.78	01:00	11:13	41.78	
SS3	Birur 1 Start	11.45			00:03	11:16		
3A/3B	Regroup In/ Service In		5.73	17.18	00:25	12:41	41.23	
	FLEXI SERVICE 'C' (Birur)	(28.95)	(46.51)	(75.46)	00:20	13:01		
3C	Service Out/ Regroup in					13:01		
	Regrouping				00:35	13:36		SEC 3
3D	Regroup Out					13:36		
4	Kuvempu University		16.50	16.50	00:30	14:06	33.00	SEC 4
SS4	Kuvempu 2 Start	17.50			00:03	14:09		
5	Birur		24.28	41.78	01:00	15:09	41.78	
SS5	Birur 2 Start	11.45			00:03	15:12		SEC 5
5A/5B	Regroup In/ Service In		5.73	17.18	00:25	15:37	41.23	
	FLEXI SERVICE 'D' (Birur)	(28.95)	(46.51)	(75.46)	00:45	16:22		
5C	Service Out/ Regroup in					16:22		
	Regrouping				00:35	16:57		
5D	Regroup Out					16:57		
5E*	ABC Parc Ferme		45.35	45.35	01:20	18:17	34.01	



Leg 1	Totals	57.90	208.57	266.47
--------------	---------------	--------------	---------------	---------------

Itinerary								
Day 2 Sunday 20th November 2011								
TC/ SS	LOCATION	SS DIST	LIASON DIST	TOTAL DIST	TARGET TIME	FIRST CAR	AVG SPEED	
5F	ABC Start					06:02		SEC 6
5G	Service In		63.00	63.00	01:20	07:22	47.25	
	Service 'E' (Birur)		(63.00)	(63.00)	00:20			
5H	Service Out					07:42		
6	Birur		5.60	5.60	00:15	07:57	22.40	
SS6	Birur (R) 1 Start	11.45			00:03	08:00		
7	Kuvempu University		24.35	35.80	01:00	09:00	35.80	SEC 7
SS7	Kuvempu University (R) 1 Start	17.50			00:03	09.03		
7A/7 B	Regroup In/ Service In		16.53	34.03	00:50	9:53	40.84	
	Flexi Service 'F' (Birur)	(28.95)	(46.48)	(75.43)	00:20	10:13		
7C	Service Out/ Regroup in					10:13		
	Regrouping				00:35	10:48		
7D	Regroup out					10:48		
SS8	Birur (R) 2 Start	11.45			00:03	11:06		SEC 8
8A*	Regroup In		33.00	44.45	01:20	12:26	33.34	



8B	Regroup out					13:26		SEC 9
9	Amber valley SSS		3.40	3.40	00:15	13:41	13.60	
SS9	Amber Valley SSS2 start	3.00				13:44		
9A	Service In G ABC		3.30	6.30	00:17	14:01		
9B	Service Out				00:20	14:21		
9C*	Parc Ferme In ABC/Finish of Rally		0.05	0.05	00:05	14:26	0.60	
	TOTAL LEG 2	46.40	154.78	198.18				
	Leg 1 Total	57.90	208.57	266.47				
	Leg 2 Total	46.40	154.78	198.18				
	Rally Total	104.30	363.35	464.65				
<p>* Denotes early check-in allowed</p> <p>At the 20 min Flexi Service crews may wait for upto 25 minutes in Regroup before entering Service without incurring penalty</p> <p>At the 45 min Flexi Service crews may wait for upto 50 minutes in Regroup before entering Service without incurring penalty</p>								



Appendix 2 Reconnaissance Schedule

Thursday 17th November 2011

SS No.	SS Name	Opens	Closes	Round
6, 8	Birur ®	08:00	08:30	1
3, 5	Birur	09:00	09:30	1
6, 8	Birur ®	10:00	10:30	2
3, 5	Birur	11:00	11:30	2
7	Kuvempu Univesity ®	12:00	12:30	1
7	Kuvempu Univesity ®	12:30	13:00	2
2, 4	Kuvempu University	14:00	14:30	1
2, 4	Kuvempu University	14:30	15:30	2

Recce No 21 and above

SS No.	SS Name	Opens	Closes	Round
2, 4	Kuvempu University	08:00	08:30	1
2, 4	Kuvempu University	08:30	09:00	1
7	Kuvempu Univesity ®	10:00	10:30	2
7	Kuvempu Univesity ®	10:30	11:30	2
6, 8	Birur ®	12:00	12:30	1
3, 5	Birur	13:00	13:30	1
3, 5	Birur	14:00	14:30	2
6, 8	Birur ®	15:00	15:30	2

Strictly Dirt Tyres will not be permitted on the stages.

All the reconnaissance regulations have to be followed.



Appendix 3 Names and Photographs of CROs**Appendix 2 : Competitor Relations Officer (s)**

Ms. Sheeren Balachandran
Mobile : +91 98860 34256

Will be present at

At Documentation
Pre Event Scrutiny
At the Secretariat
At the Start of the Rally
At Spectator Super Special Stage
At Service Park
Near the Parc Ferme at the Finish
Podium Finish



Appendix 4: Penalties

Art.No.	Reason/s
START REFUSED	
4.5 (SR)	Entry Fees not paid
5.4 (SR)	High Risk Insurance for Crew
5.5 (SR)	Special Rally Cover Insurance for competing cars
22.3	No Reconnaissance
40.2	Reporting to start more than 30 minutes late than scheduled start time
EXCLUSION	
12.3	Absence of entry in Time Card
17.1.4	Driving in opposite direction in Special Stage
17.3.6	3 rd infringement of Traffic Laws
27.5.1	Incorrect sequence / direction of Rally
30.1	Exceeding MPL 30 minutes
33.4.3	Unable to start within 20 secs of start signal in Special Stage
REPORT TO STEWARDS	
11	Deviation of itinerary in Road Book
12.1 (SR)	Very Late Reporting to Ceremonial Start
17.2.3	Excessive Speeding in Reconnaissance
22.3	Non participation in Reconnaissance, not adhering to schedule and number of passage
24.2.2, 24.2.3	Missing / tampering of identification mark
27.6.1	Not following instruction of control marshals
33.4.2	Refusing to start in Special Stage in allotted time
33.6	more than 3 infringements of false start
34.1	Stopping between the yellow warning sign and the stop sign



36.2.8	Non reporting of crew retirement
36.3	Non reporting of Accident to member of Public to the next radio point
36.4.1	Failure to place Red Triangle
36.5.1	No reduction of speed, follow marshals instruction on deployment of Yellow Flag
43.3	Speeding more than 30 kmph in Service Park

Art.No.	Reason	Penalty
Time / Monetary Penalty		
17.2.2	Excessive Speeding in Reconnaissance – 1 st infringement	Rs.5,000/-
17.3.4	Traffic Law – 1 st infringement	Rs.5,000/-
17.3.5	Traffic Law – 2 nd infringement	5 mins
29.2.10a	Late arrival at TC	10 sec / min or fraction of minute
29.2.10b	Early arrival at TC	1 min / min or fraction of minute
33.4.1	Start delay due to fault of crew	1 min / min or fraction of minute
33.6	False Start – 1 st offence	10 secs
33.6	False Start – 2 nd offence	1 minute
33.6	False Start – 3 rd offence	3 minutes
38.4.3	Repair time taken in Parc Ferme beyond originally scheduled start time	1 min / min or fraction of minute
Appdx 5	Missing of competition number	Rs.2,500/-
11.2 (SR)	Ineffective or missing mud flap	Rs.1,000/-
12.1(SR)	Late reporting to holding area at Ceremonial Start	Rs.500/- per min



Appendix 5: Compulsory & Optional Advertisements

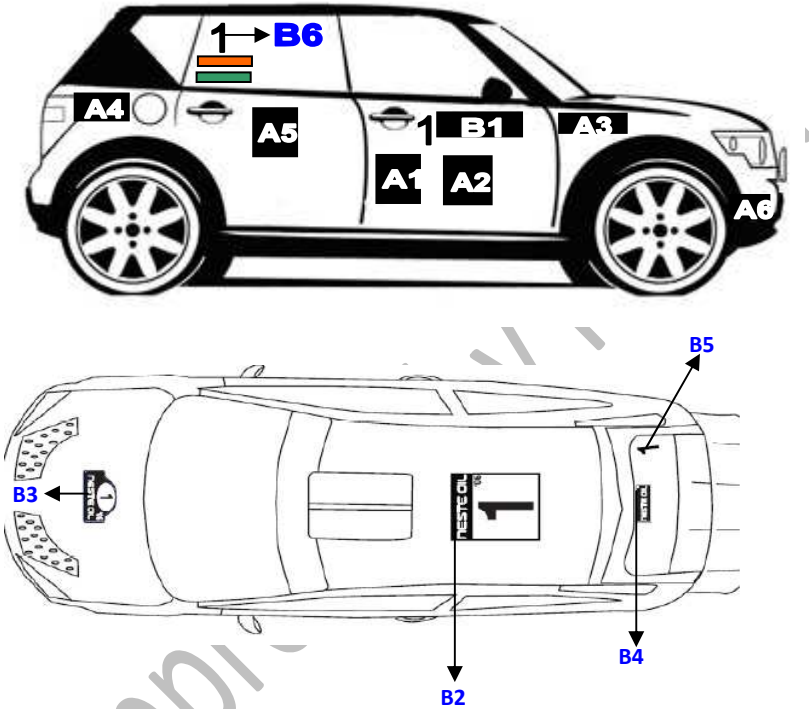

Compulsory Advertisement

B1	Front Door Panel	48 cm X 20 cm
B2	Roof Panel	50 cm X 52 cm
B3	Bonnet Panel	43 cm X 21.5 cm
B4	Rear Window Panel	30 cm X 10 cm
B5		15 cm X 14 cm
B6	Side Window Panel	25 cm (Stroke width 25 mm)



Optional Advertisement

- A1 MAK Lubricants
- A2 Organizer
- A3 TBA
- A4 TBA
- A5 IMG Sports
- A6 TBA

Approved by FMSCI

