



APPROVED



ROTAX MOJO MAX Challenge Technical Regulations 2012

(The Technical Regulations 2012 replace the Technical Regulations 2011)
Version ~~23.12.2011~~ 26.01.2012 (revisions acc. Bulletin 1-2012 / 27.02.2012)



- Note: Rules written in 10 points are valid for national RMC's only
- Note: Rules written in 12 points are valid for national RMC's, IRMCE's and RMCGF

1. Categories:

Karts used in the ROTAX MOJO MAX Challenge (RMC), ROTAX MOJO MAX Challenge GRAND FINAL (RMCGF) and International ROTAX MOJO MAX Challenge Events (IRMCE) like the ROTAX MOJO MAX EURO Challenge are divided into the following groups:

- ROTAX 125 Junior MAX (cylinder capacity 125 cc)
- ROTAX 125 MAX/MASTERS (cylinder capacity 125 cc)
- ROTAX 125 MAX DD2/MASTERS (cylinder capacity 125 cc, 2-speed)

2. Amount of equipment:

For each race event (from non-qualifying practice to the final) maximum following amount of equipment is allowed:

- 1 chassis
- 2 sets of dry tires + 1 front + 1 rear spare tire
- 2 sets of wet tires + 1 front + 1 rear spare tire
- 2 engines

3. Kart:

3.1 Chassis:

125 Junior MAX- and 125 MAX classes

For national RMC's any chassis sanctioned by an authorized ROTAX distributor is allowed.

Chassis tubing : round tubing only.

Maximum diameter of rear axle = 50 mm, minimum wall thickness according to CIK-FIA rules.

At IRMCE and RMCGF chassis with a valid CIK-FIA homologation only are allowed.

Any brake system must have a valid CIK-FIA homologation.

Front brakes are not allowed in the 125 Junior MAX class.

Front brakes are allowed in 125 MAX class only but may be forbidden by the authorized distributor or by a race promoter in accordance with the authorized distributor.



125 MAX DD2 / DD2 MASTERS

For all national RMC, IRMCE and the RMCGF 125 MAX DD2 /DD2 MASTERS classes, chassis approved by BRP-POWERTRAIN only are allowed to be used (approved chassis will be listed at the web page: www.maxchallenge-rotax.com).

Chassis must be designed according to CIK-FIA rules for shifter classes (front- and rear brakes mandatory).

Any brake system must have a valid CIK-FIA homologation.

ROTAX Rear Tire Protection System is mandatory to be used. Either old 2 tube version or latest 3 tube version, third tube might be mounted above or below the 2 main tubes.

No part shall be added or removed from original content (except safety wire as well as number plate with support)

3.2 Bodywork

125 Junior MAX- and 125 MAX/MAX MASTERS classes

In accordance with regulations of national Federations or CIK-FIA.

At RMCGF and IRMCE bodywork with current CIK-FIA homologation validity only is allowed, including the rear wheel protection system.

125 MAX DD2 / DD2 MASTERS class

In accordance with regulations of national Federations or CIK-FIA.

At RMCGF and IRMCE bodywork with current CIK-FIA homologation validity only is allowed. Only the current ROTAX rear wheel protection system is allowed.

4. Tires

At all RMC, IRMCE following tires only are allowed:

Dry (slick) tires:	MOJO	Type:	D1, D2 or D3		
		Front:	4.5 x 10.0 - 5	Rear:	7.1 x 11.0 - 5
Wet tires:	MOJO	Type:	W2		
		Front:	4.0 x 10.0 - 5	Rear:	6.0 x 11.0 - 5

At all RMC Micro Max / Mini Max following tires only are allowed:

Dry (slick) tires:	MOJO	Type:	C2 or CX		
		Front:	4.0 x 10.0 - 5	Rear:	5.0 x 11.0 - 5
Wet tires:	MOJO	Type:	CX		
		Front:	4.0 x 10.0 - 5	Rear:	5.0 x 11.0 - 5

At RMCGF following tires only are allowed

125 Junior MAX					
Dry (slick) tires:	MOJO	Type:	D1		
		Front:	4.5 x 10.0 - 5	Rear:	7.1 x 11.0 - 5
Wet tires:	MOJO	Type:	W2		
		Front:	4.5 x 10.0 - 5	Rear:	6.0 x 11.0 - 5
125 MAX/Masters					
Dry (slick) tires:	MOJO	Type:	D2		
		Front:	4.5 x 10.0 - 5	Rear:	7.1 x 11.0 - 5
Wet tires:	MOJO	Type:	W2		
		Front:	4.5 x 10.0 - 5	Rear:	6.0 x 11.0 - 5

125 MAXDD2 Masters					
Dry (slick) tires:	MOJO	Type:	D3		
		Front:	4.5 x 10.0 - 5	Rear:	7.1 x 11.0 - 5
Wet tires:	MOJO	Type:	W2		
		Front:	4.5 x 10.0 - 5	Rear:	6.0 x 11.0 - 5

Strictly no modifications or tire treatment allowed.

Marked direction of rotation must be adhered to for all tires.

If tires are checked for modification we recommend MiniRAE Lite equipment.

5. **Data acquisition:**

This system, with or without a memory, may permit only the reading/recording of: the engine revs (by induction on the sparkplug HT cable), two indications of temperature, the speed of one wheel, an X/Y acceleration, lap times and position (via GPS system)

6. **Composite materials:**

Composite materials (carbon fiber etc.) are banned except for the seat and the floor tray. Alloys from different metals/substances are not considered as composite materials (for example brake disks)

7. **Safety of equipment**

For RMCGF and IRMCE article 3 of CIK-FIA technical regulations apply.

For RMC overalls, helmets, kart shoes, gloves and other kind of driver protection must comply with the regulations of the national Federation or CIK-FIA.

8. **Petrol / Oil**

Petrol: Unleaded commercial quality from petrol station, maximum 98 octane.

Oil: XPS-Karttec 2-stroke oil (CIK homologation no. 110162/01 or)

9. Engines

At RMC, RMCGF and IRMCE races, engines which are confirm to the following technical specification only, are legal to be used.

For national RMC's, engines are allowed to be used only, which have been checked and sealed by the ROTAX Authorized Distributor of this territory or one of the Service Centers appointed by the Authorized Distributor.

For national RMC's the ROTAX Authorized Distributor of this territory has to publish the lists of Service Centers which are legal to check and seal engines.

For IRMCE all ROTAX Authorized Distributors and their Service Centers only are allowed to check and seal engines.

ROTAX will publish a list of Authorized Distributors and their Service Centers which are legal to check and seal engines.

For RMCGF ROTAX only is allowed to check and seal engines.

By sealing an engine the ROTAX Authorized Distributors and their Service Centers take over the responsibility for the conformity of the engine with according to the valid Technical Specification. Also a brand new engine must be checked according to the Technical Specification before sealing.

The engines have to be sealed with specific ROTAX engine seals (black anodized aluminium seal with "ROTAX "-logo and a 6 digit serial number and a barcode).

Further legal seals are:

- black anodized aluminium seals with "JAG"-logo and 6 digit serial number
- red anodized aluminium seals with "JAG"-logo and 6 digit serial number
- red anodized seals with "KORRIDAS" and 6 digit serial number
- ~~orange~~ blue anodized seals with 6 digit serial number



By means of the steel cable the engine must be sealed on one Allen screw (1) of the intake flange, on one stud screw (2) of cylinder and one Allen screw (3) of the cylinder head cover (see attached pictures).

After sealing the engine seal thread must be squeezed using ROTAX caliper 276 110. (see picture below)

ONLY SEALS WITH BARCODE ARE LEGAL TO BE USED !

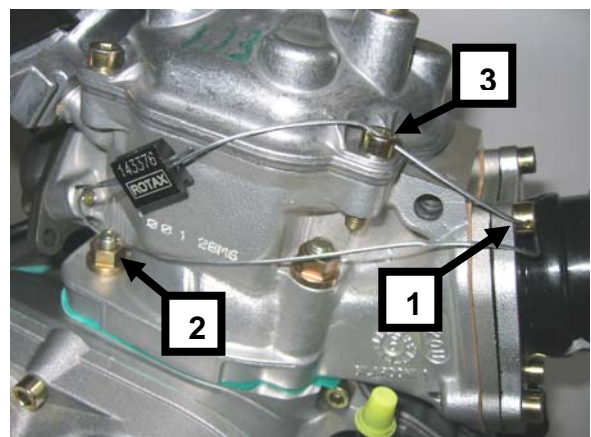
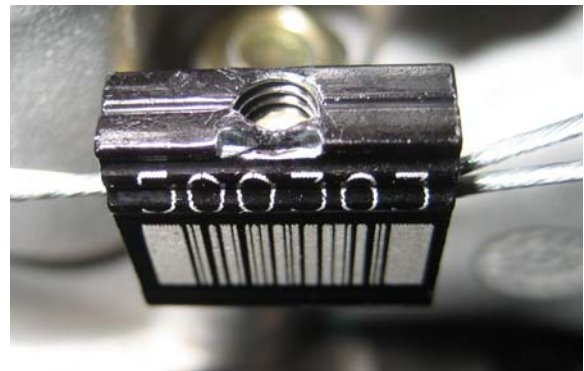

It is not allowed to pass the end of the sealing wire through the seal a second time (only as in above picture)

At every new sealing of an engine the authority (ROTAX Authorized Distributor or their Service Centers) that checks and seals an engine is responsible for following indications at the Engine Identity Card which belongs to the owner of the engine.

- Serial no. of the engine
- Serial no. of the engine seal
- Stamp and signature of the company to be able to detect at scrutineering which authority has checked and sealed the engine.



At scrutineering the driver has to present

- the engine(s) with the undamaged engine seal(s)
- the Engine Identity Card(s), showing the matching engine serial no.(s), the matching engine seal no.(s) and the stamp(s) and signature(s) of the authority(ies) that has (have) checked and sealed the engine(s).

The ROTAX Authorized Distributor organizing a national RMC may appoint before every RMC race a neutral Service Center which will be the only one allowed to re-seal an engine between scrutineering and the final in the case of an engine failure.

During an IRMCE ROTAX Authorized Distributors and their Service Centres are not allowed to re-seal an engine between scrutineering and the final.

The sealing of engines helps to reduce the times for scrutineering at races as during the race event just the accessories (carburetor, exhaust, radiator.....) must be checked.

Of course scrutineers can request to open and re-check an engine according to the Technical Specification, before or after a race or in case of a protest. If an engine seal has been broken (for which reason ever), the engine has to be checked completely according to the Technical Specification and must then be re-sealed by an ROTAX authorized Distributor or one of its Service Centers.

Neither the engine nor any of its ancillaries may be modified in any way. "Modified" is defined as any change in form, content or function that represents a condition of difference from that originally designed. This is to include the addition and/or omission of parts and/or material from the engine package assembly unless specifically allowed within these rules. The adjustment of elements specifically designed for that purpose shall not be classified as modifications, i.e. carburetor and exhaust valve adjustment screws.

The repair of a thread on the crankcase (maximum of one threaded hole per engine) using a "heli-coil" or similar is allowed.

Exception: the threads located under the crankcase to fix the crankcase on the engine mount may be repaired as needed.



Genuine ROTAX components only, that are specifically designed and supplied for the 125 Junior MAX-, the 125 MAX- and the 125 MAX DD2 engine are legal, unless otherwise specified.

ANYTHING WHICH IS NOT EXPRESSILY ALLOWED IN THE TECHNICAL REGULATIONS IS FORBIDDEN.

Internal additions:

No additional material may be added except in the case of engine repairs and shall only restore the engine or components to original specifications.

The use of thermal barrier coatings/ceramic coatings on or in the engine and on or in the exhaust system is prohibited.

The use of anti-friction coatings in or on the engine/engine components is prohibited.

Customizing the cylinder head cover by painting is legal

Legal additions:

Chain guard, engine mount, temperature gauge and tachometer/hour meter, inline fuel filter, catch can mounting brackets and supplemental ignition coil mounting brackets, within the limits specified in this document.

Non-tech items:

Non-original fasteners, circlips, washers, electrical mass cable, throttle cable housing, fuel and pulse line (type and size) as well as length of coolant hoses are allowed unless otherwise specified.”

Note:

When taking any dimensional reading, of the following technical regulation, in the order of accuracy of 0,1 mm or even more precise, the temperature of the part must be between +10°C and +30°C.

Note:



Before taking any decision based on this regulation a check for available bulletins is mandatory. They can be found under www.maxchallenge-rotax.com

To avoid excessive noise and exhaust emissions raving the kart in the servicing park is not allowed (except a short function test)

It is the responsibility of the competitor to check his equipment (all components outside the engine seal and mentioned below), to assure that his equipment is in line with the technical specification below!

9.1 Technical Specification (within the engine seal) for ROTAX kart engines 125 Junior MAX (15 kW) 125 MAX (21 kW).

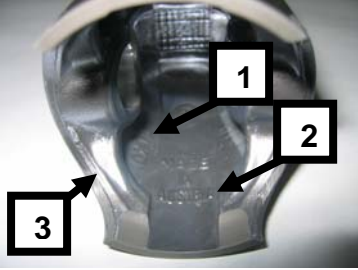
Squish gap	1.1 1.2	125 Junior MAX 1,20 mm - 1,80 mm 125 MAX 1,00 mm - 1,50 mm
		<p>The squish gap must be measured with a certified slide gauge and by using a 2 mm tin wire. The crankshaft must be turned by hand slowly over TDC (top dead center) to squeeze the tin wire.</p> <p>The squish gap must be measured on the left and right side in the direction of the piston pin.</p> <p>The average value of the two measurements counts.</p> <p>Recommended 2mm tin wire : part no. 580 130</p>
Combustion chamber insert	2.1 2.2 2.3 2.4	<p>Cast identification (pos. 1) code has to be "223 389" or "223 389 1" or "223 389 2" or 223 389 2/1"</p> <p>Casted wording (pos. 2) "ROTAX" and/or (pos.3)"MADE IN AUSTRIA" must be shown.</p> <div data-bbox="695 775 1066 1081" data-label="Image"> </div> <p>Heights of combustion chamber insert have to be 27,55 mm with a tolerance of +0,0/-0,1 mm (A) and 28,80 mm with a tolerance of +/- 0,2 mm (B).</p> <p>The profile of the combustion chamber insert has to be checked with a template (ROTAX part no. 277 390). The crack of light between the template and the profile of the combustion chamber insert has to be the same over the whole profile.</p> <div data-bbox="711 1462 1342 1608" data-label="Diagram"> </div> <p>NOTE: This check is just for reference, in case of doubt detailed measurements have to be performed to define conformity or non conformity.</p> <div data-bbox="1157 1724 1517 1989" data-label="Image"> </div>

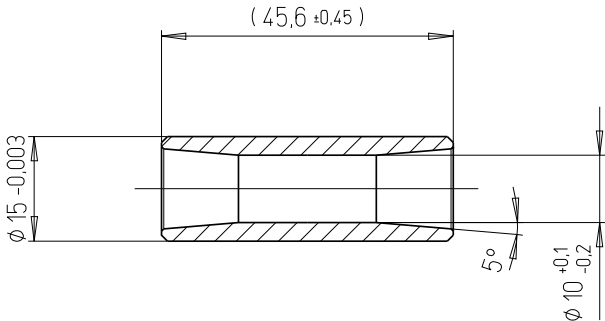
<p>Piston with ring assy.</p>	<p>3.1 3.2 3.3 3.4</p>	<p>Original, coated or uncoated, aluminium, cast piston with one piston ring. The piston has to show on the inside the cast wording "ELKO" (1) and "MADE IN AUSTRIA" (2).</p> <p>Machined areas are: Top end of piston, outside diameter, groove for the piston ring, bore for the piston pin, inside diameter at bottom end of piston and some pre-existing factory removal (3) of flashing at the cut out of the piston skirt. All other surfaces are not machined and have cast surface.</p>  <p>Original, magnetic, rectangular piston ring. Ring height : <u>0,98 +/- 0,02 mm</u> Piston ring is marked either with "E CRY K" or "ROTAX 215 547" or "ROTAX 215 548".</p>  <p>TYPICAL PICTURE</p> <p>"Window" type piston as delivered in the early days of production is no longer legal to be used.</p>	
<p>Gudgeon pin</p>	<p>4.1 4.2 4.3</p>	<p>Gudgeon pin is made out of magnetic steel. Dimensions must be according to the drawing. The minimum weight of the gudgeon pin must not be lower than 32,10 grams.</p> 	

Cylinder	<p>5.1</p> <p>5.2</p> <p>5.3</p> <p>5.4</p> <p>5.5.1</p>	<p>Light-alloy-cylinder with GILNISIL-plating. Any re-plating of cylinder is not allowed.</p> <p>Cylinder with one main exhaust port.</p> <p>Maximum bore of cylinder = 54,035 mm (measured 10 mm above the exhaust port).</p> <p>Cylinder has to be marked with the "ROTAX" logo (see pictures below).</p> <p>125 Junior MAX Cylinder without pneumatic timed exhaust valve. Cylinder has to be marked either with identification code 223 999, 223 998 or 223 994</p> 
	5.5.2	<p>125 MAX Cylinder with pneumatic timed exhaust valve. Cylinder has to be marked either identification code 223 997, 223 996 or 223 993</p> 

5.6

Height of cylinder has to be 87 mm $-0,05/+0,1$ mm.



5.7.1

All transfer ports and passages have cast finish surface except some removal (done by the manufacturer) of cast burr at the inlet passage. and exhaust port and passages. All ports have chamfered edges to prevent ring snagging. Any additional machining is not permitted. The top edge of exhaust port may show some pre-existing machining from the manufacturer. The sealing flange for the exhaust socket may show signs of machining from the manufacturer.

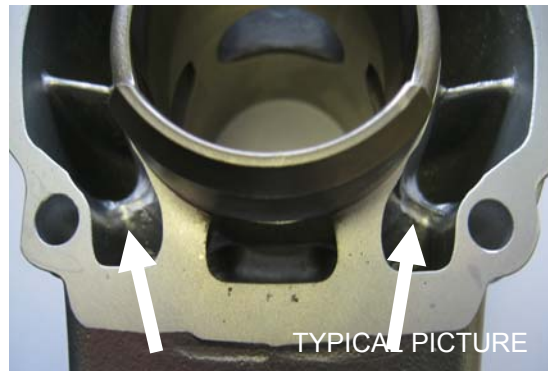

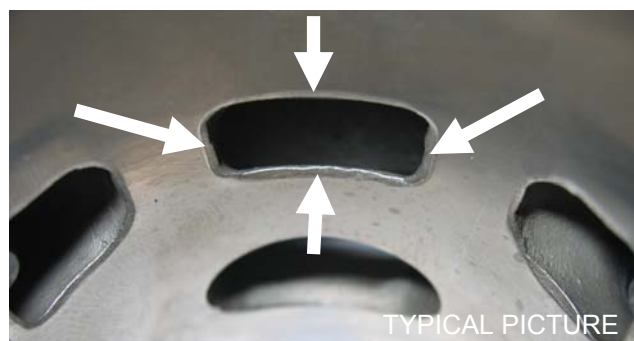

5.7.2

All ports have chamfered edges. Any additional machining is not permitted.



On cylinders marked 223 993 and 223 994 the upper edge of the central boost port may show factory machining.

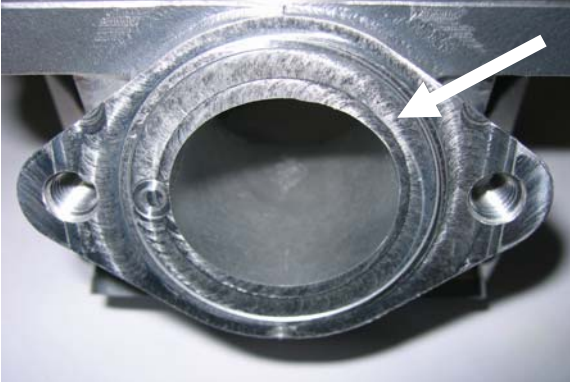

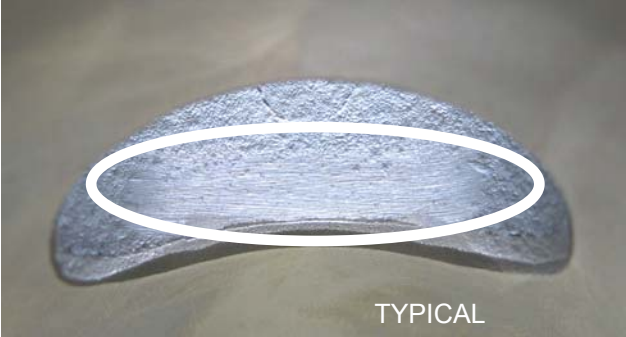
	5.7.3	<p>The sealing flange for the exhaust socket may show either cast finish surface or signs of machining from the manufacturer.</p> 
	5.7.4	<p>The top edge of the exhaust port may show either just a cast finish surface...</p>  <p>or signs of a CNC machining ...</p>  <p>or signs of CNC machining in combination with signs of manual grinding.</p>  <p>The exhaust port may show partial manual grinding done by the manufacturer to eliminate minor casting defects and to eliminate the NIKASIL burr at the end of the NIKASIL plating.</p>

At cylinders 223 993 and 223 994 exhaust port may show factory machining all around



5.8

Exhaust port timing

The "exhaust port timing" (distance from the top of the cylinder to the top of the exhaust port) has to be checked by means of the template (ROTAX part no. 277 397).

Insert the template into the cylinder, that the template is touching the cylinder wall and that the finger of the template is located in the middle of the exhaust port (highest point).



Move the template upwards, until the finger is touching the top edge of the exhaust port. Insert a filler gauge between the top of the cylinder and the template. It must not be possible to fit the feeler gauge specified below.

125 Junior MAX: 0,90 mm for cylinder 223 999 / 998
1,10 mm for cylinder 223 994
125 MAX: 0,75 mm

At cylinders 223 993 (125 MAX) it is also legal if the template doesn't fit in at all.

NOTE: Take care to use the corresponding gauge (JUN or MAX) of the template for the respective cylinder!



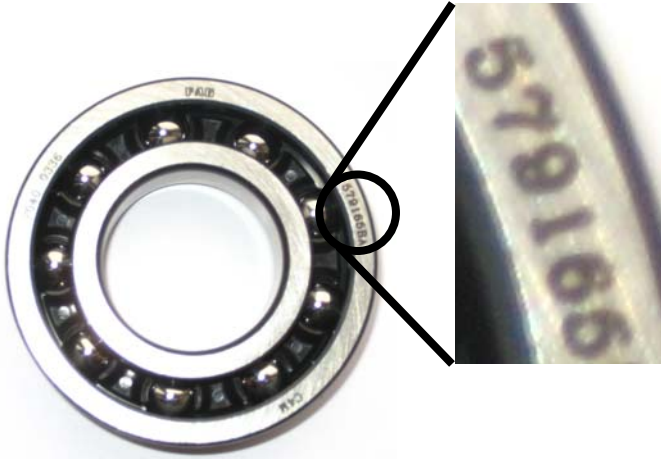
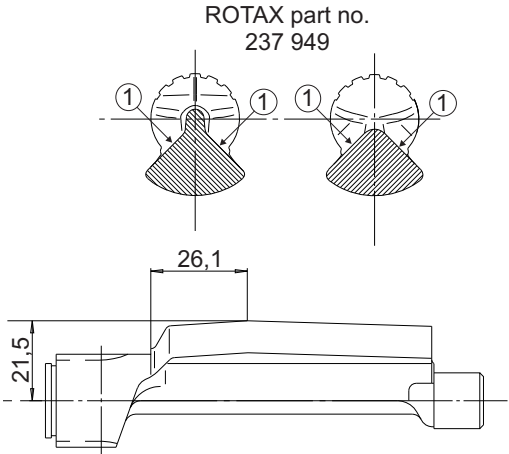

	5.9	<p>Exhaust valve (125 MAX only) If the piston is moved in direction top of cylinder and first time covering completely the exhaust port, it must be possible to insert the exhaust valve gauge (ROTAX part no. 277 030) until it stops at the surface of the cylinder (a feeler gauge of 0,05 mm must not be possible to fit in).</p> 
Inlet system	6.1	<p>Inlet manifold is marked with the name "ROTAX" and the identification code "267 915".</p>  <p>6.2 Some factory flash removal may be present at the conjunction of the inside contour and the carburetor stop mounting face. This is a manual trimming operation consisting of a small corner break of less than 3 mm in width. No additional grinding or machining is permitted.</p> <p>6.3 The reed valve assy. is equipped with 2 pedal stops and 2 reeds, each having 3 pedals.</p> <p>6.4 The thickness of the reeds is 0,6 mm +/- 0,10 mm.</p>
Crankshaft	7.1 7.2 7.3	<p>7.1 Stroke 54,5 mm +/-0,1 mm</p> <p>7.2 Con rod has to show forged numbers "213", "365" or "367" on shaft.</p>  <p>7.3 Shaft of con rod is not machined (copper plated). Grinding of polishing of shaft of con rod is not permitted.</p>

	7.4	<p>Crankshaft main bearing 6206 from FAG only is allowed. (must be marked with code 579165BA or Z-579165.11.KL)</p> 
Balance shaft	8.1 8.2 8.3 8.4 8.5	<p>Balance shaft and balance gears must be installed.</p> <p>Configurations of part no. 237 949 (equal with 237 948) only is legal.</p> <p>Surface (1) is not machined and must show cast surface.</p> <p>Measurement from center of balance shaft to outer diameter of fly weight of balance shaft at defined length must not be lower than specified.</p> <p>The minimum weigh of the dry balance shaft must not be lower than:</p> <p>255 grams for balance shaft ROTAX part no. 237 949 (equal with 237 948).</p> 
Crankcase	9.1	<p>As supplied by the manufacturer. No grinding/polishing is permitted in the two main transfer passages as well as in the crank area.</p>

9.2 Technical Specification (outside the engine seal) for ROTAX kart engines 125 Junior MAX (15 kW) 125 MAX (21 kW).

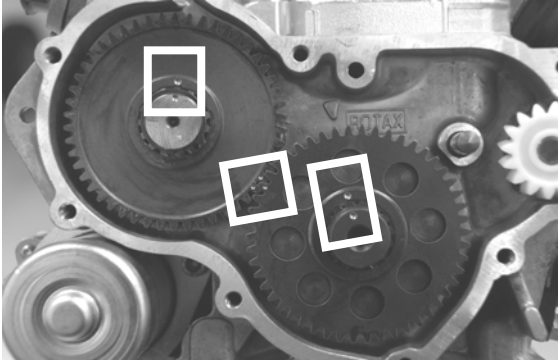
It is the responsibility of the competitor to check his equipment (all components outside the engine seal and mentioned below), to assure that his equipment is in line with the technical specification below!

Balance drive	10.1	Only steel balance ears are legal to be used.
	10.2	<p>Balance gears must be installed and must be aligned according to the instruction in the repair manual.</p>  <p>Mixing of steel balance gears of different width (6,0 and 9,0 mm) is strictly forbidden.</p>

<p>Ignition system</p>	<p>11.1</p> <p>11.2</p> <p>11.3</p> <p>11.4</p> <p>11.5</p> <p>11.6</p>	<p>DENSO digital battery ignition, variable ignition timing, no adjustment necessary and possible. Race officials may request at any time that the competitor replace the ignition coil with <u>another</u> new unit provided by the race administration. ←</p> <p>The casting of the ignition coil has to show the following in casting "129000-" and "DENSO".</p> <p>Ignition coil must show 3 pins at the terminal.</p> <p>Connector housing of ignition coil must have either black or green color.</p> <p>Version as in attached picture with an extension wire (number 265571 engraved as in picture) is not legal to be used any more as of 01.03.2012. ←</p>  <p>The ignition coil has to be fixed by means of 2 original silent blocks to the gearbox cover. Only in case of chassis component interference with the original mounting location of the ignition coil, a supplementary extension bracket, rigidly constructed and fabricated of solid metal, of minimum dimensions and attached to the original case mounting holes, is permitted for mounting of the coil.</p> <p>Minimum length of ignition wire (high tension wire) is 210 mm from outlet of cable at ignition coil to outlet of cable at spark plug connector (= the visible length of wire) Ignition coil must be in working condition (to be tested in case of doubt)</p>
------------------------	---	---

11.7 The pick up must be marked with the numbers 029600-0710, followed by a variable production code in the 2nd line.

HINT: In case of doubt an easy check is to place a steel ball (3-5 mm in diameter) on the pickup (engine side), the steel ball must stay in the center of the pickup surface.



11.8 Spark plug: DENSO Iridium IW 24 or 27 or 29 or 31 or 34

11.9 Spark plug cap must be marked with "NGK TB05EMA".

11.10 Original battery must be used,
YUASA YT7B-BS
ROTAX RX7-12B or RX7-12L (lithium iron phosphate type)

11.11 Battery must be fitted with the original battery clamp and battery cover (see illustration below) and must be fixed to the chassis with at least 2 screws.
Position of the battery is free.

11.12 Battery must be mounted with all components as shown in the illustration below

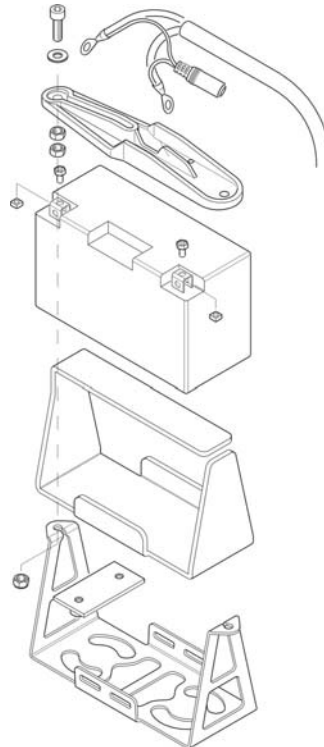

Centrifugal clutch

13.1

Dry centrifugal clutch, engagement maximum at 4.000 r.p.m.

That means, that the kart (without driver) must start to move latest at an engine speed of maximum 4.000 r.p.m.

There are two versions of the clutch shoe (element part # 3 on the diagram) and both are legal to be used. The older version of the clutch shoe can be either untreated or nitrated configuration

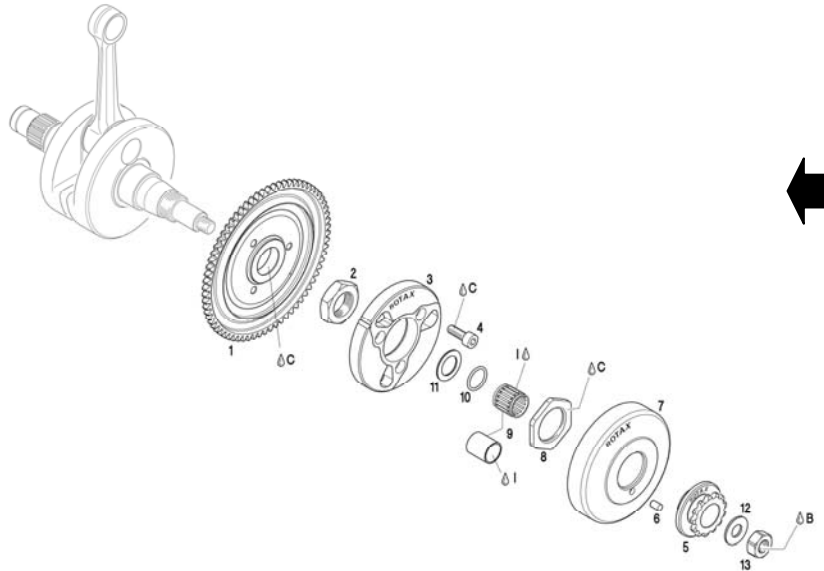

Engines must be fitted the new needle cage bearing (item 9) 15X19X17 or plain bearing 15X17X17,6 (for 11 teeth sprocket) as well as new O-Ring 12X2,5 (item 10) only.

13.2

~~Except if the plain bearing 15X17X20 (item 9) designed for 11 teeth sprocket is used, in this case no O-ring must be used.~~

No extra lubrication or additional substance allowed inside the clutch drum additional to the grease that originates from lubrication of the needle cage bearing and enters the clutch area.



Picture shows worst case scenario in case grease exits the bearing area even O-Ring is installed.

Only fixation nut as well as inside of drum show signs of grease, running surface of clutch is completely dry.

In case Plain bearing for 11teeth sprocket is used clutch area must be absolutely free grease or any additional substance. ←

Steel clutch (both versions) and clutch drum must be within following specifications.

Height of clutch

13.3

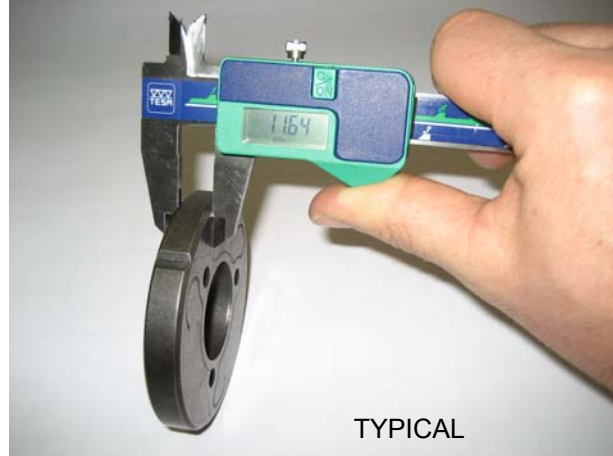

Minimum: 11,45 mm.

13.3.1

Thickness of clutch shoe



Measurement has to be done at the 3 open ends of the clutch shoes, 5 - 10 mm from the machined groove (all clutch shoes must be completely closed at measurement - no gap).

No measurement may be below 24,10 mm.

13.3.2 **Outer diameter of clutch drum**

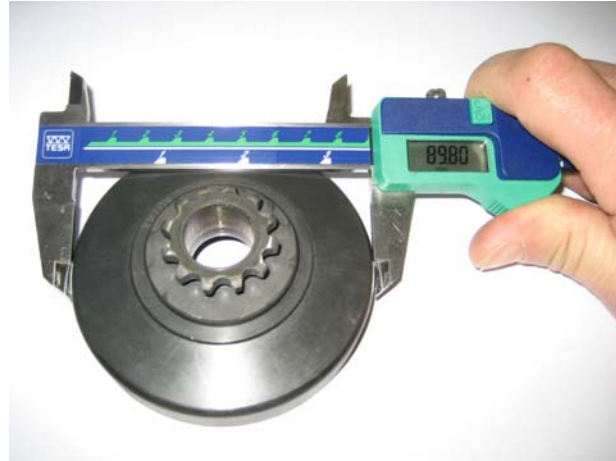

Diameter has to be measured with a sliding caliper just beside the radius from the shoulder (not at the open end of the clutch drum).

Minimum diameter: 89,50 mm.

13.3.3 **Inner diameter of clutch drum**



The inner diameter has to be measured with a sliding calliper. The measurement has to be done in the middle of the clutch drum (in the contact area of the clutch drum).

Maximum diameter: 84,90 mm.



13.3.4 Height of sprocket with clutch drum assmbly.

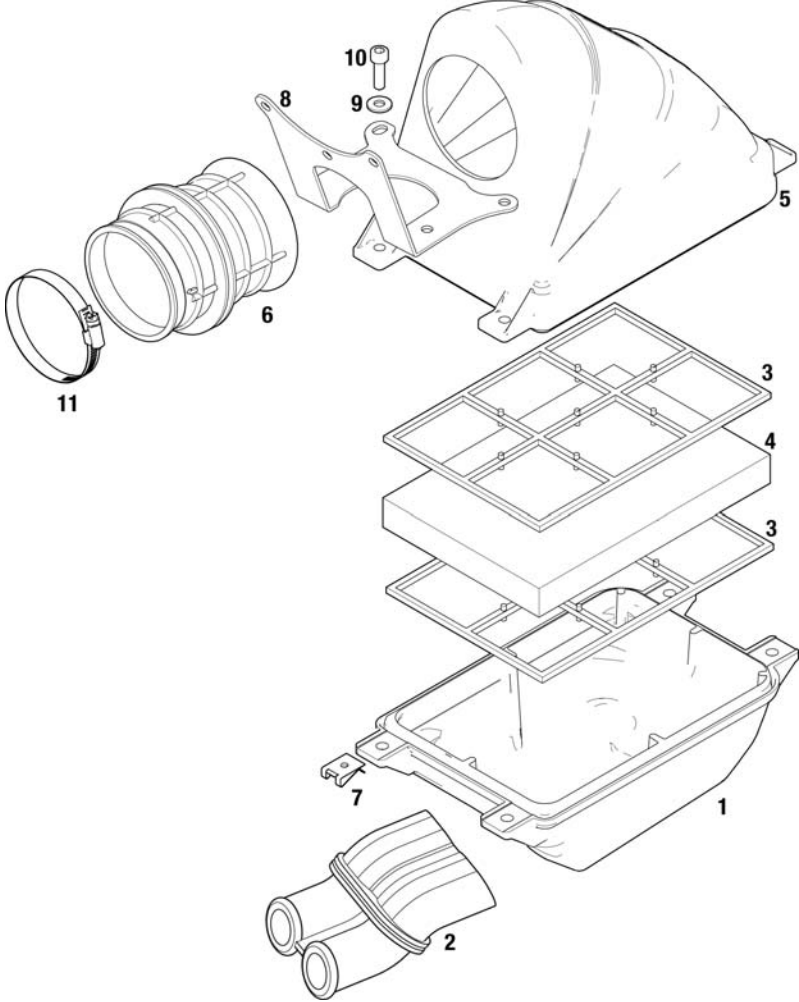

Minimum height: 33,90 mm

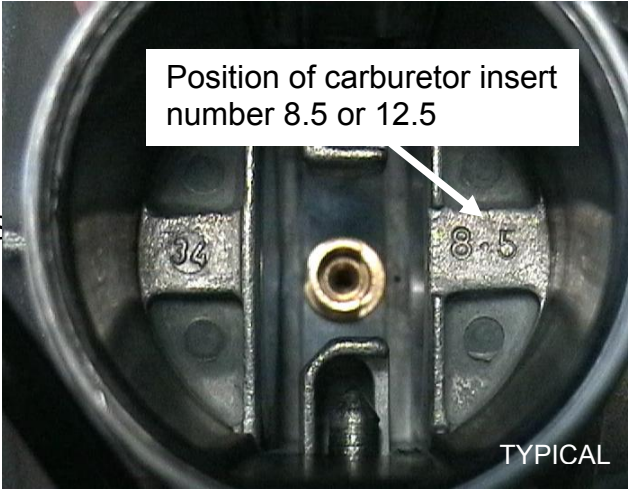
<p>Intake silencer</p>	<p>14.1</p>	<p>Intake silencer with integrated, washable air filter has to be used with all parts as shown at illustration and has to be mounted on the support bracket with two screws (in dry and wet race condition).</p> <p>Intake silencer tube (pos 2) as well as carburetor socket (pos 6) are only legal if marked with "ROTAX".</p> <p>Parts marked with "APRILIA" are no longer legal to be used.</p> 
<p>-</p>	<p>14.2</p>	<p>Intake silencer case bottom is marked on the inside with the ROTAX part no. 225 015.</p>
<p>-</p>	<p>14.3</p>	<p>Intake silencer case, top is marked on the inside with the ROTAX part no. 225 025.</p>
<p>-</p>	<p>14.4</p>	<p>Air filter must be installed as shown in illustrations above.</p>

Carburetor	15.1	DELL'ORTO carburetor
	15.2	VHSB 34" cast in the housing of the carburetor.
	15.3	"QD" or "QS" stamped in the housing of the carburetor.
	15.4	Needle jet stamped with "FN 266"
	15.5	The complete inlet bore in the casting of the carburetor must show cast surface.
	15.6	The carburetor slide must show with size "40" in casting and the bottom end of the slide must show cast surface.
	15.7	Jet needle stamped with "K98" only
	15.8	Following two combination of floats and idle jets are legal:
	15.8.1	Combination 1: Floats are marked with "gr 5.2" Idle jet is stamped with the digits "30" Idle jet insert is stamped with digits "30" Carburetor insert 12.5 (see illustration)
	15.8.2	Combination 2: Floats are marked with "gr 3.6" Idle jet is stamped with the digits "60" Idle jet insert is stamped with digits "60" Carburetor insert 8.5 (see illustration)
		
	15.9	Needle valve is stamped "150"
	15.10	Start jet is stamped with digits"60"
	15.11	Settings of the carburetor adjustment screws are free.
	15.12	A minimum required size of main jet may be determined for each race event by a "Supplementary Regulation".

	15.13	<p>Optional carburetor plug screw (ROTAX part number 261030) is legal to be used.</p> 
Fuel pump	16.1	<p>MIKUNI diaphragm pump, must be mounted on the support bracket (on the bottom or sideways) for the intake silencer.</p>
Fuel filter	17.1	<p>The 2 original fuel filter versions only (see attached pictures) are allowed to be fitted between the fuel tank and the fuel pump.</p>  <p>No additional parts except the fuel line, the fuel pump as well as the original fuel filter are legal to be mounted between fuel tank and carburetor.</p>

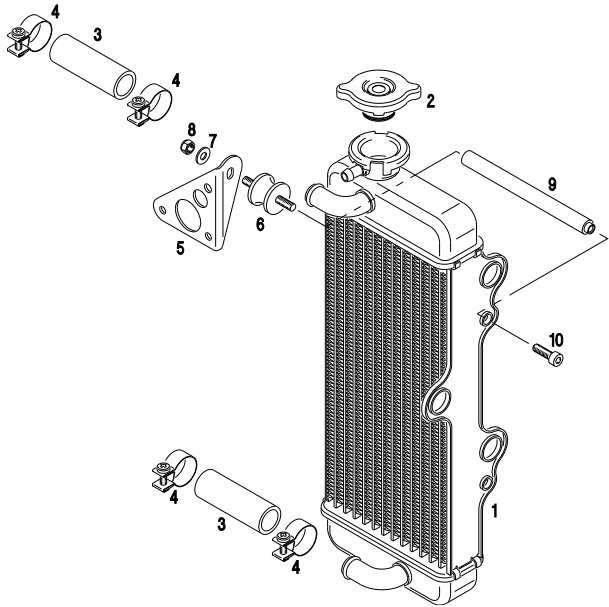
Radiator	18.1	<p>Single aluminium radiator as shown in illustrations Name "ROTAX" stamped in the side of version 3.</p> <p>18.2 Version 1/2: Cooling area: Height:290 mm, width:133 mm Version 3: Cooling area: Height:290 mm, width:138 mm</p> <p>18.3 Version 1/2: Thickness of radiator = 32 mm Version 3: Thickness of radiator = 34 mm</p> <p>18.4 Place of fixing the radiator is on right side of engine.</p> <p>18.5 Radiator must be mounted with all components as shown in the illustration either like version 1/2 or like version 3.</p> <p>18.6 At version 2 there is 2 legal options to mount the radiator to the retaining plate (see drawing for details) At version 2 there is 2 different radiator with 2 different positions of the retaining plates (either pointing forward or backwards)</p> <p>18.7 No additional non original cooling device is allowed.</p> <p>For version 1 and 2 tape applied around the radiator is the only allowed air flow control. Tape may not be removed from the radiator during operation on the track. All other means of air flow control through the radiator are prohibited. For version 3 the original plastic flap is the only way to control the airflow. Removal of the original plastic flap as well as use of tape, like for the version 1 and 2 of the radiator, is an acceptable configuration.</p> <p>18.8 The removal of the thermostat from the cylinder head cover is an acceptable configuration.</p> <p>Version 1</p> 
----------	------	--

Version 2

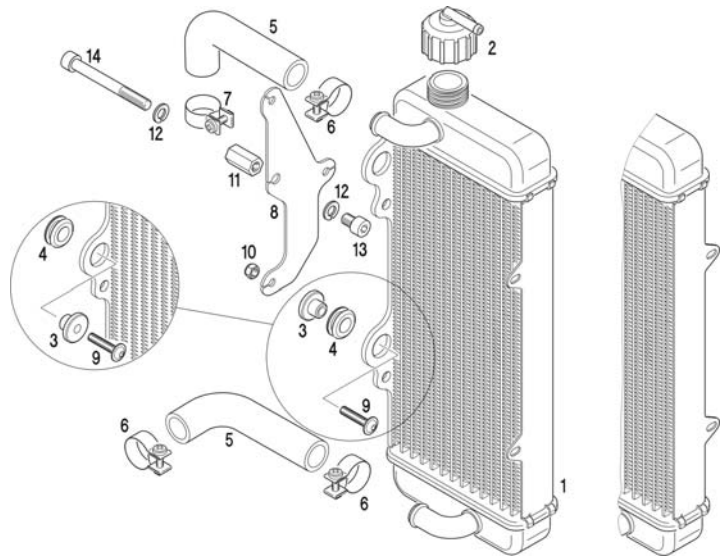

Version 3

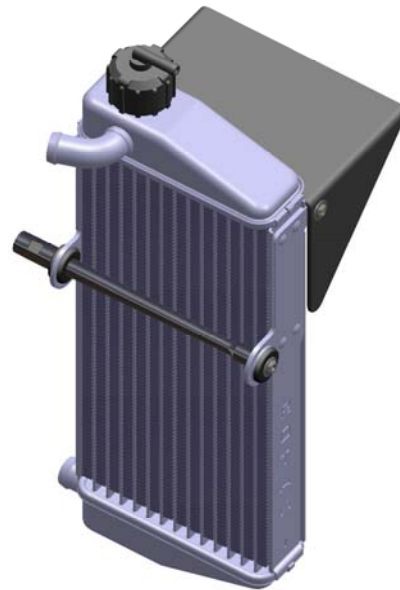

Radiator coolant



19.1

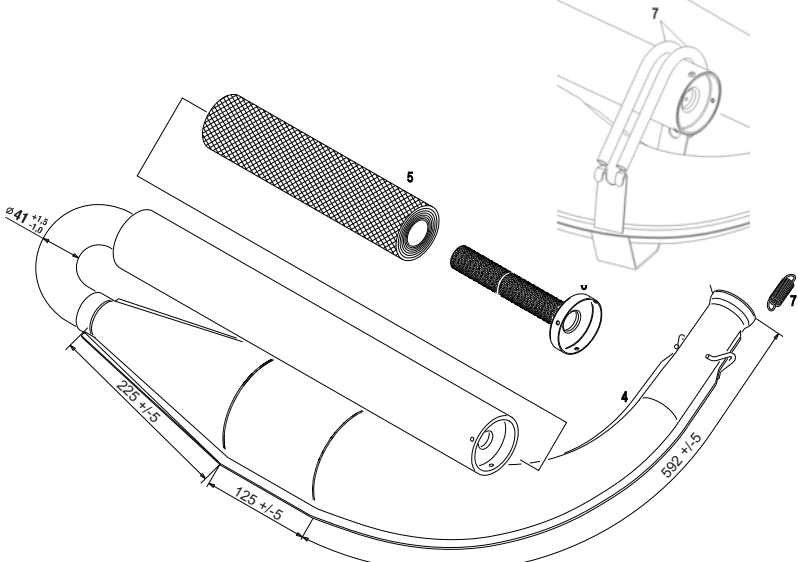

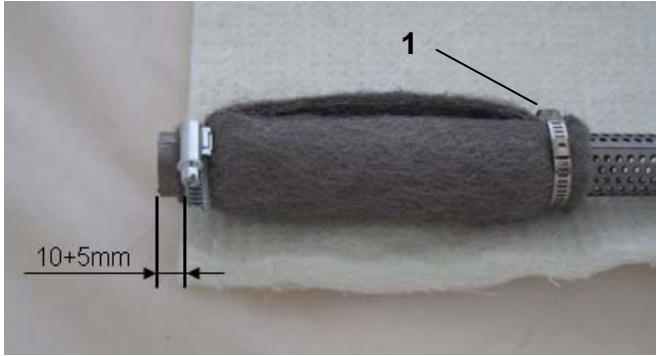
As glycol coolants are prohibited, plain water without any additives has to be used.

<p>Exhaust system</p>	<p>20.1</p> <p>20.2</p> <p>20.3</p>	<p>Must be as supplied by BRP-POWERTRAIN and cannot be modified except for the replacement of the silencer absorption material and the use of threaded fasteners in place of the rivets for securing the silencer end cap.</p> <p>Standard exhaust socket must be used.</p> <p>Exhaust pipe with after muffler as shown in illustrations. Both versions (version with welded on after muffler and version with after muffler fixed by 2 springs) are legal to be used.</p>  <p style="text-align: right;">Illustration 7</p> <p>20.4 Diameter of hole of end cap of (pos 6, illustration above): Max. 21,0 mm</p> <p>20.5 Length of inlet cone: 592 mm +/-5 mm (measured on outside from beginning of exhaust pipe until beginning of cylindrical part).</p> <p>20.6 Length of cylindrical part of exhaust pipe: 125 mm +/-5 mm.</p> <p>20.7 Length of end cone: 225 mm, +/-5 mm</p> <p>20.8 Outside diameter of 180° bent tube: 41mm +1,5 mm/-1,0 mm (measured at beginning and end of bend).</p> <p>20.9 Just one piece of original isolating mat is allowed to be used. The original exhaust system (tuned pipe and silencer) may not be modified, except for the addition of extra elements for further noise reduction.</p>
-----------------------	-------------------------------------	---

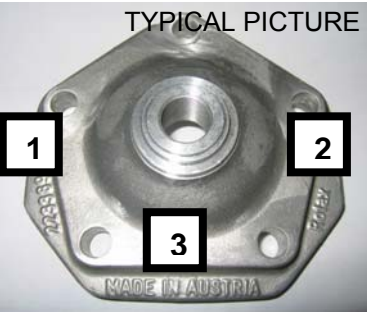
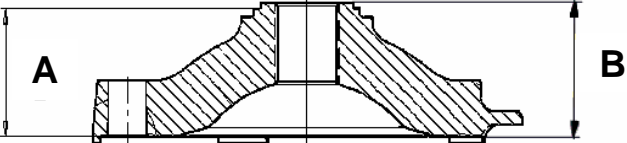
	<p>20.10</p> <p>20.11</p> <p>20.12</p> <p>20.13</p>	<p><u>Additional to the standard isolation mat a special steel isolation mat of the square dimension of 165 +10 mm is legal (not mandatory) to be assembled underneath the standard isolation mat as in following illustration. (Rotax part number of kit 297983).</u></p> <p><u>Clamp (1) as included in the kit is optional:</u></p>  <p>For measuring the exhaust gas temperature, it is allowed to weld on a socket on top of the exhaust, 50 mm from the ball joint.</p> <p>The use of maximum 4 pieces of original BRP-POWERTRAIN exhaust springs to fix the exhaust to the cylinder are allowed. (no safety wire allowed in exhaust flange area).</p> <p>Unpainted exhaust system as delivered in the first years of production is not legal to be used.</p>
<p>Noise emissions</p>	<p>21.1</p> <p>21.2</p>	<p>Noise isolating mat (see illustration exhaust system) has to be replaced by a original BRP-POWERTRAIN spare part, if the noise emission is exceeding 92 dB (A).</p> <p>Noise emission measuring procedure: The measuring place has to be at section of the track where the engine is operated under full load and at a rpm range of 11.000 to 12.000 rpm. The microphone has to be installed 1 meter above the level of the track in a rectangular angle to the track. The distance between the microphone and the kart on the ideal line on the track has to be 7,5 meters. The kart has to be operated under full load at the ideal line on the track.</p>

9.3 Technical Specification (within the engine seal) for ROTAX kart engine 125 MAX DD2 (24 kW).

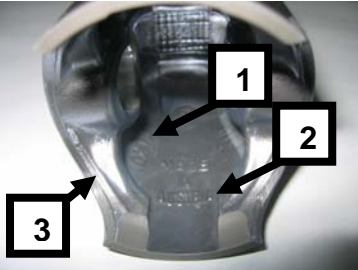
Squish gap	1.1	<p>125 MAX DD2 1,10 mm - 1,50 mm</p> <p>The squish gap must be measured with a certified slide gauge and by using a 2 mm tin wire. The crankshaft must be turned by hand slowly over TDC (top dead center) to squeeze the tin wire. The squish gap must be measured on the left and right side in the direction of the piston pin. The average value of the two measurements counts. Recommended 2 mm tin wire : part no. 580 130</p>
Combustion chamber insert	<p>2.1</p> <p>2.2</p> <p>2.3</p> <p>2.4</p>	<p>Cast identification (pos. 1) code has to be "223 389" or "223 389 1" or "223 389 2" or 223 389 2/1"</p> <p>Casted wording (pos. 2) "ROTAX" and/or (pos.3) "MADE IN AUSTRIA" must be shown.</p>  <p>Heights of combustion chamber insert have to be 27,55 mm with a tolerance of +0,0/-0,1 mm (A) and 28,80 mm with a tolerance of +/- 0,2 mm (B).</p> <p>The profile of the combustion chamber insert has to be checked with a template (ROTAX part no. 277 390). The crack of light between the template and the profile of the combustion chamber insert has to be the same over the whole profile.</p>  <p>NOTE: This check is just for reference, in case of doubt detailed measurements have to be performed to define conformity or non conformity.</p> 

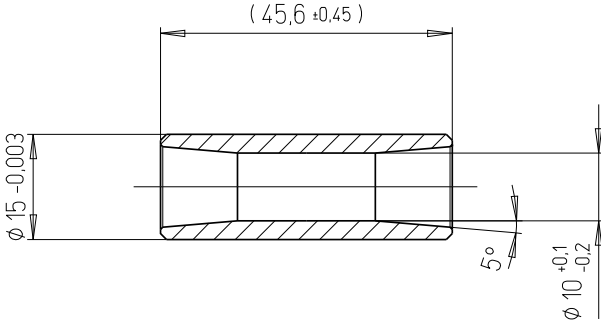
<p>Piston with ring assy.</p>	<p>3.1 3.2 3.3 3.4</p>	<p>Original, coated or uncoated, aluminium, cast piston with one piston ring. The piston has to show on the inside the cast wording "ELKO" (1) and "MADE IN AUSTRIA" (2).</p> <p>Machined areas are: Top end of piston, outside diameter, groove for the piston ring, bore for the piston pin, inside diameter at bottom end of piston and some pre-existing factory removal (3) of flashing at the cut out of the piston skirt. All other surfaces are not machined and have cast surface.</p>  <p>Original, magnetic, rectangular piston ring. Ring height : <u>0,98 +/- 0,02 mm</u> Piston ring is marked either with "E CRY K" or "ROTAX 215 547" or "ROTAX 215 548".</p>  <p>TYPICAL PICTURE</p> <p>"Window" type piston as delivered in the early days of production is no longer legal to be used.</p>
<p>Gudgeon pin</p>	<p>4.1 4.2 4.3</p>	<p>Gudgeon pin is made out of magnetic steel. Dimensions must be according to the drawing. The minimum weight of the gudgeon pin must not be lower than 32,10 grams.</p> 



<p>Cylinder</p>	<p>5.1 5.2 5.3 5.4 5.5</p>	<p>Light-alloy-cylinder with GILNISIL-plating. Any re-plating of cylinder is not allowed.</p> <p>Cylinder with one main exhaust port and two side exhaust ports. Maximum bore of cylinder = 54,035 mm (measured 10 mm above the exhaust port).</p> <p>Cylinder has to be marked with the "ROTAX" logo (see picture below).</p> <p>Cylinder with pneumatic timed exhaust valve.</p> <p>Cylinder has to be marked with the identification code 613 930, 613 931. or 613 933</p> <div data-bbox="608 490 1366 1032" data-label="Image"> <p>The image contains three photographs of a light-alloy cylinder head, showing the 'ROTAX' logo and identification codes. The top-left photo shows code '613930'. The top-right photo shows code '613931' with '220U 2' below it. The bottom photo shows code '613933' with '220Y A' below it.</p> </div>
-----------------	--	---

5.6

Height of cylinder has to be 86,7 mm $-0,05/+0,1$ mm.



5.7.1

All transfer ports and passages have cast finish surface except some removal (done by the manufacturer) of cast burr at the inlet passage and exhaust port and passages. All ports have chamfered edges to prevent ring snagging. Any additional machining is not permitted. The top edge of exhaust port may show some pre-existing machining from the manufacturer. The sealing flange for the exhaust socket may show signs of machining from the manufacturer.

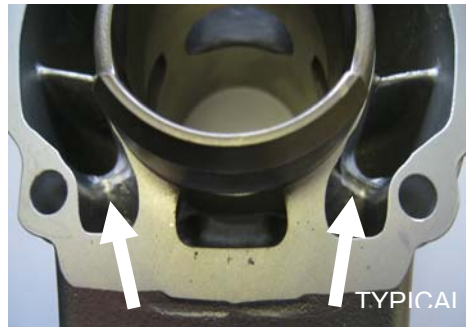

5.7.2

All ports have chamfered edges.
Any additional machining is not permitted.

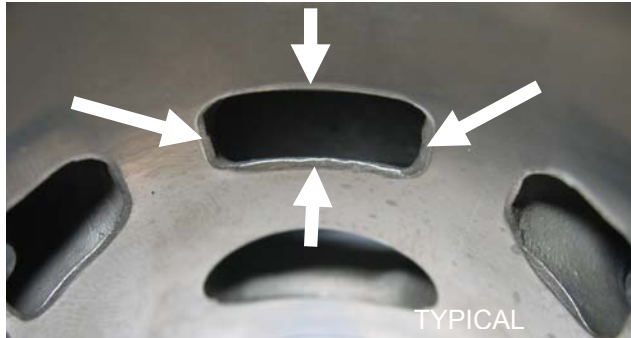

On cylinders marked 613 933 the upper edge of the central boost port may show factory machining.

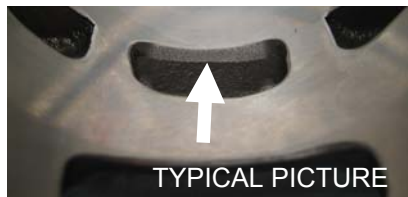

5.7.3

The sealing flange for the exhaust socket may show either cast finish surface or signs of machining from the manufacturer.



5.7.4

The top edge of the exhaust port may show either just a cast finish surface...



or signs of a CNC machining ...

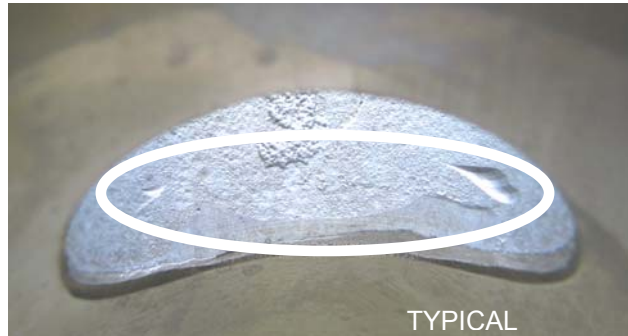

or signs of CNC machining in combination with signs of manual grinding.

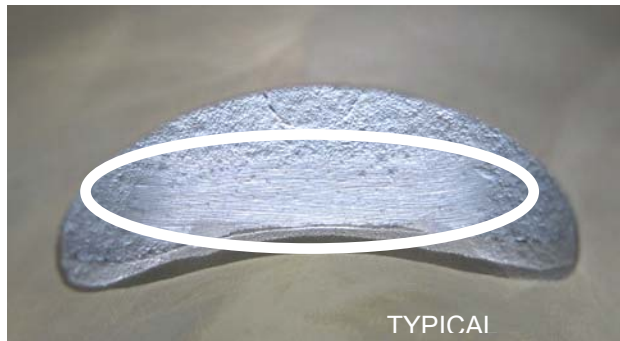

The exhaust port may show partial manual grinding done by the manufacturer to eliminate minor casting defects and to eliminate the NIKASIL burr at the end of the NIKASIL plating.

At cylinder 613 933 exhaust port may show factory machining all around



5.8

Exhaust port timing

The "exhaust port timing" (distance from the top of the cylinder to the top of the exhaust port) has to be checked by means of the template (ROTAX part no. 277 397).

Insert the template into the cylinder, that the template is touching the cylinder wall and that the finger of the template is located in the middle of the exhaust port (highest point).



Move the template upwards, until the finger is touching the top edge of the exhaust port. Insert a filler gauge between the top of the cylinder and the template. It must not be possible to fit the feeler gauge specified below.

125 MAX DD2 : 0,75 mm

At cylinders 613933 (125 MAX DD2) it is also legal if the template doesn't fit in at all.





NOTE: Take care to use the corresponding gauge of the template (DD2) for the respective cylinder!

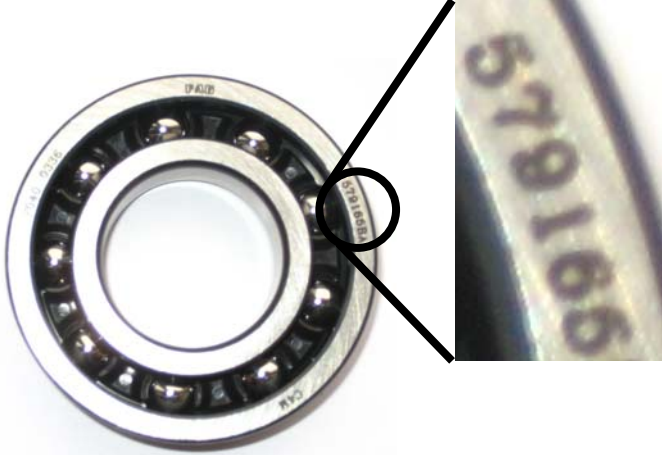

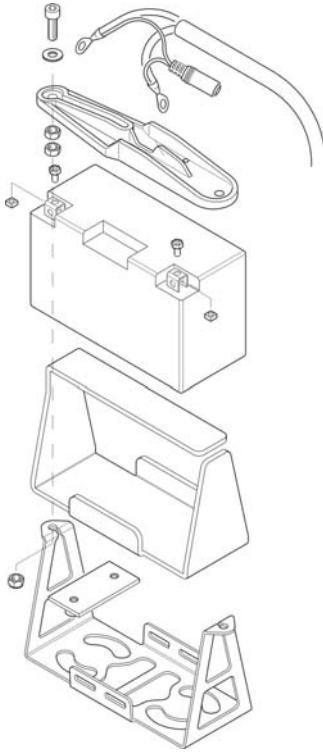
	5.9	<p>If the piston is moved in direction top of cylinder and first time covering completely the exhaust port, it must be possible to insert the exhaust valve gauge (ROTAX part no. 277 030) until it stops at the surface of the cylinder (a feeler gauge of 0,05 mm must not be possible to fit in)</p> 
Inlet system	6.1	<p>Inlet manifold is marked with the name "ROTAX" and the identification code "267 410".</p>  <p>6.2 Some factory flash removal may be present at the conjunction of the inside contour and the carburetor stop mounting face. This is a manual trimming operation consisting of a small corner break of less than 3 mm in width. No additional grinding or machining is permitted.</p> <p>6.3 The reed valve assy. is equipped with 2 pedal stops and 2 reeds, each having 3 pedals.</p> <p>6.4 The thickness of the reeds is 0,6 mm +/- 0,10 mm.</p>

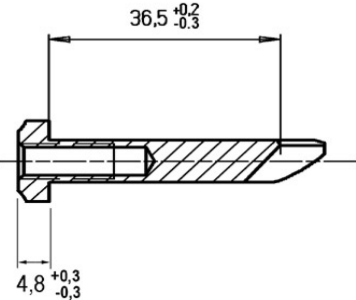
Crankshaft	7.1 7.2 7.3 7.4	<p>Stroke 54,5 mm +/-0,1 mm Con rod has to show forged numbers "213", "365" or "367" on shaft.</p>  <p>Shaft of con rod is not machined (copper plated). Grinding or polishing of shaft of con rod is not permitted.</p> <p>Crankshaft main bearing 6206 from FAG only is allowed. (must be marked with code 579165BA or Z579165.11.KL)</p> 
2-speed gearbox	8.1 8.2 8.3	<p>Primary shaft with 19 teeth for 1st gear and 24 teeth for 2nd gear. Idle gear for 1st gear has to have 81 teeth. Idle gear for 2nd gear has to have 77 teeth.</p>
Crankcase	9.1	<p>As supplied by the manufacturer. No grinding/polishing is permitted in the two main transfer passages as well as in the crank</p>

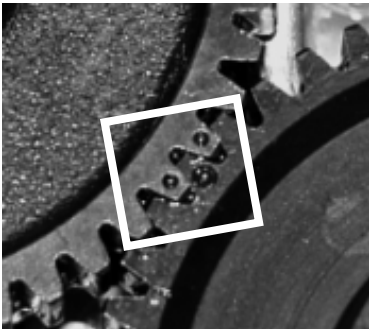
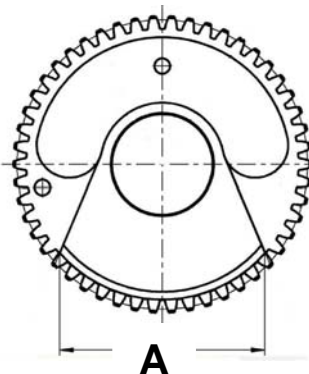
	<p>10.10</p> <p>10.11</p> <p>10.12</p>	<p>Spark plug: DENSO Iridium IW 24 or 27 or 29 or 31 or 34 Spark plug cap must be marked with "NGK TB05EMA".</p> <p>Original battery must be used, YUASA YT7B-BS ROTAX RX7-12B or RX7-12L (lithium iron phosphate type)</p> <p>Battery must be fitted with the original battery clamp and battery cover (see illustration below) and must be fixed to the chassis with at least 2 screws. Position of the battery is free.</p> <p>Battery must be mounted with all components as shown in the illustration below</p> 
--	--	--

<p>Exhaust valve</p>	<p>11.1 11.2 11.3 11.4</p>	<p>As supplied by the manufacturer with no modification allowed. Compression spring must be fitted. Length of the exhaust valve is 36,5 mm +0,20 mm /-0,30 mm. Width of collar is 4,8 mm +/-0,3 mm</p>  <p>Exhaust valve bellow Only the green colored exhaust valve bellow is legal to be used (ROTAX part number 260723)</p>
<p>Balance drive</p>	<p>12.1 12.2 12.3 12.4 12.5</p>	<p>Balance drive gear must be fitted on crank shaft. Balance gear must be fitted on primary shaft and must be aligned with the balance drive gear according to the instruction in the repair manual. Fly weight of balance gear must show cast surface (old version only)</p>   <p>New version</p>   <p>Fly weight of balance gear can show machined surface (new version only). Dimension A (widest part of balance weight) must be either 53 mm +/- 0,5 or <u>57</u> mm +/- 0,5</p> <p>The minimum weight of a dry balance gear including bearing (new version only) must not be lower than 240 grams</p>

Centrifugal clutch

13.1

Dry centrifugal clutch, engagement r.p.m. maximum at 4.000 r.p.m.
That means, that the kart (without driver) must start to move latest at an engine speed of maximum 4.000 r.p.m.
Both clutch element versions as in illustration are legal to be used.
Old version clutch element can be either untreated or nitrated configuration.

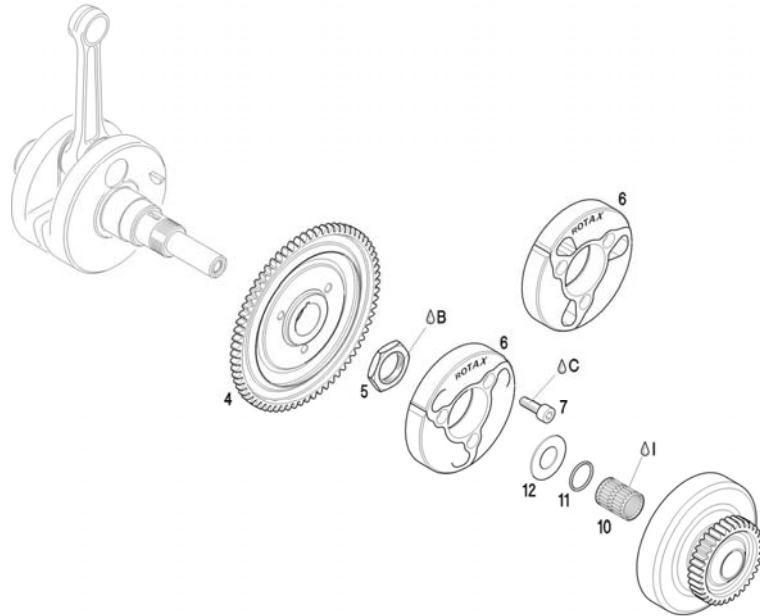

13.3

Steel clutch and clutch drum of new clutch version must be within following specifications.

13.3.1

Height of clutch

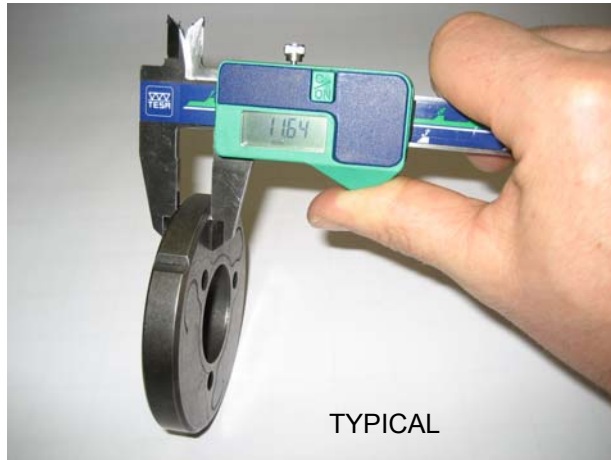

Minimum: 14,45 mm.

13.3.2

Thickness of clutch shoe



Measurement has to be done at the 3 open ends of the clutch shoes, 5 - 10 mm from the machined groove (all clutch shoes must be completely closed at measurement - no gap). No measurement may be below 24,10 mm.

13.3.3 **Outer diameter of clutch drum**



Diameter has to be measured with a sliding caliper just beside the radius from the shoulder (not at the open end of the clutch drum).
Minimum diameter: 89,50 mm.

13.3.4 **Inner diameter of clutch drum**

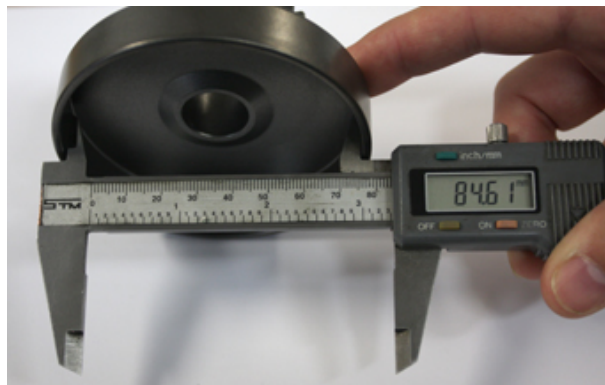

The inner diameter has to be measured with a sliding caliper. The measurement has to be done in the middle of the clutch drum (in the contact area of the clutch drum).
Maximum diameter: 84,90 mm.

13.3.5 **Height of sprocket with clutch drum assy.**



Minimum height: 39,50 mm

Primary drive

14.1

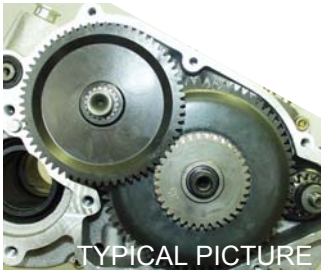
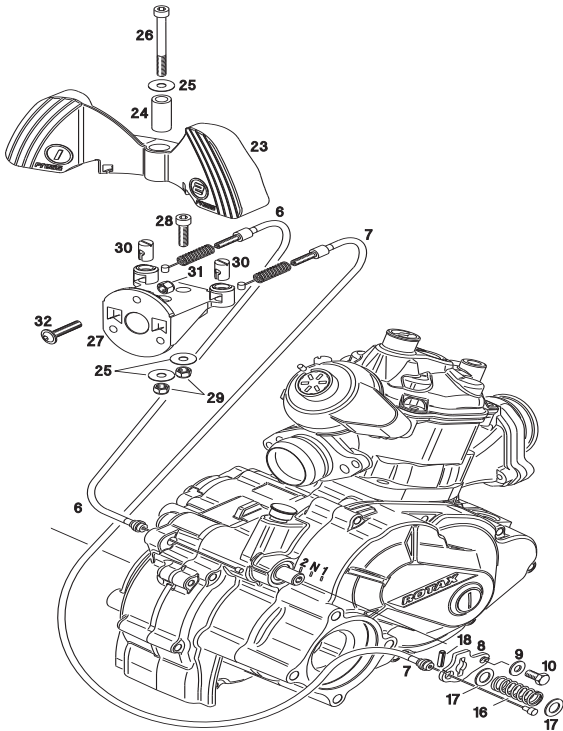

Original primary drive gears of following gear ratio options must be used. Only mentioned pairs are legal to be used

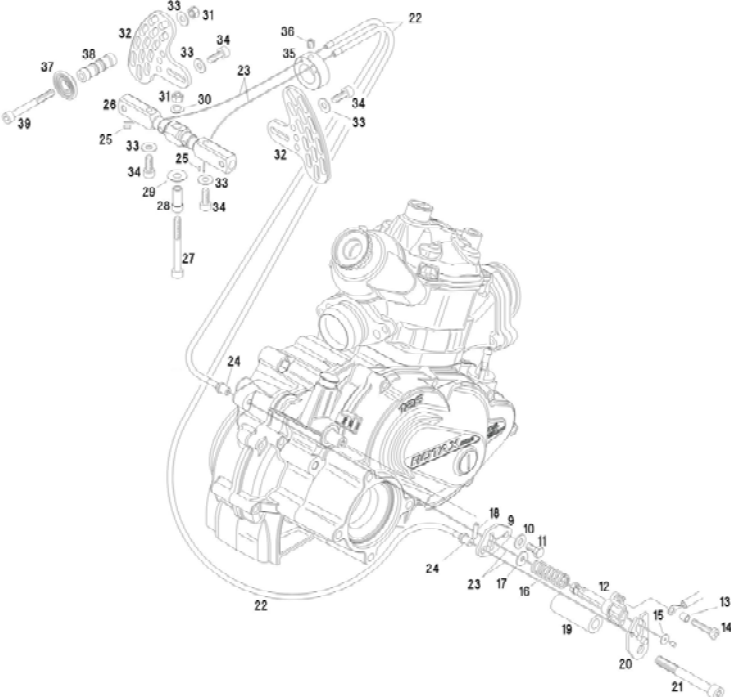
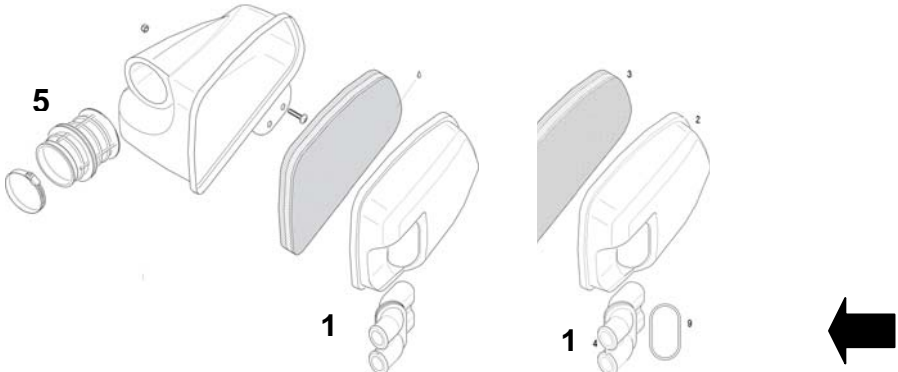

		<table border="0"> <tr> <td>Drive gear</td> <td>Driven gear</td> <td></td> </tr> <tr> <td>32</td> <td>65</td> <td></td> </tr> <tr> <td>33</td> <td>64</td> <td></td> </tr> <tr> <td>34</td> <td>63</td> <td></td> </tr> <tr> <td>35</td> <td>62</td> <td></td> </tr> <tr> <td>36</td> <td>61</td> <td></td> </tr> <tr> <td>37</td> <td>60</td> <td></td> </tr> <tr> <td>38</td> <td>59</td> <td></td> </tr> </table> <div style="text-align: right; margin-top: 10px;">  </div>	Drive gear	Driven gear		32	65		33	64		34	63		35	62		36	61		37	60		38	59	
Drive gear	Driven gear																									
32	65																									
33	64																									
34	63																									
35	62																									
36	61																									
37	60																									
38	59																									
Gear shifting	<p>14.2</p> <p>15.1</p> <p>15.2</p> <p>15.3</p>	<p>A specific primary gear ratio may be determined for each race event by a "Supplementary Regulation".</p> <p>The 2-speed gearbox has to be operated with the one of the 2 available original supplied shift paddle configurations on the steering wheel via the two cable bowden</p> <p>Cutting of the original shift paddle or adding of pads to the shift paddle is allowed to adjust the paddle to specific steering wheels (for plastic paddle only) For aluminium paddle version no cutting or adding of non original parts or material is allowed.</p> <p>Original hub for steering wheel must be used (for plastic paddle only)</p> <p>Version 1 (plastic paddle)</p> <div style="text-align: center; margin-top: 20px;">  </div>																								

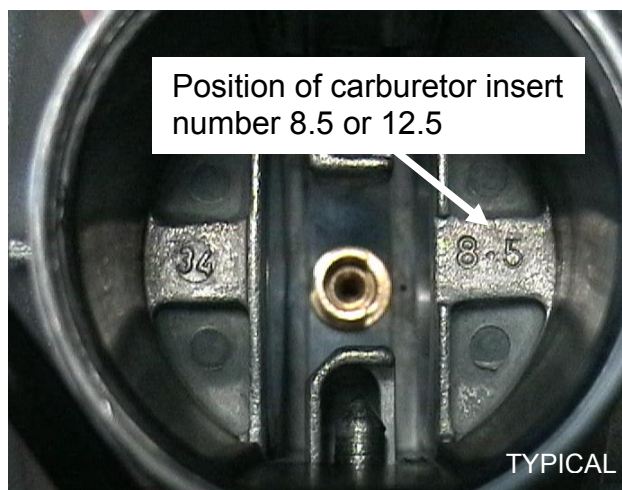
		<p>Version 2 (aluminium paddles)</p> 
Intake silencer	<p>16.1 16.2 16.3 16.4 16.5 16.6</p>	<p>Intake silencer with integrated, washable air filter as shown in illustration below (2 legal versions available).</p> <p>The intake silencer case is marked on the inside with the ROTAX part no. 225 012.</p> <p>The intake silencer cover is marked on the inside with the ROTAX part no. 225 022.</p> <p>The air filter is marked with the ROTAX part no. 225 052.</p> <p>The air filter must be assembled between the intake silencer case and the intake silencer cover that the whole area of the intake silencer case is covered.</p> <p>In case of a wet race it's allowed to seal the top of the airbox using adhesive tape.</p> <p>Version 1 (without o-ring) Version 2 (with o-ring)</p>  <p>Intake silencer tube (pos <u>1</u>) as well as carburetor socket (pos 5) are only legal if marked with "ROTAX". Parts marked with "APRILIA" are no longer legal to be used.</p>

Carburetor	17.1	DELL'ORTO carburetor
	17.2	VHSB 34" cast in the housing of the carburetor.
	17.3	"QD" or "QS" stamped in the housing of the carburetor.
	17.4	Needle jet stamped with "FN 266"
	17.5	The complete inlet bore in the casting of the carburetor must show cast surface.
	17.6	The carburetor slide must show with size "40" in casting and the bottom end of the slide must show cast surface.
	17.7	Jet needle stamped with "K98"
	17.8	Following two combination of floats and idle jets are legal:
	17.8.1	Combination 1: Floats are marked with "gr 5.2" Idle jet is stamped with the digits "30" Idle jet insert is stamped with digits "30" Carburetor insert 12.5 (see illustration)
	17.8.2	Combination 2: Floats are marked with "gr 3.6" Idle jet is stamped with the digits "60" Idle jet insert is stamped with digits "60" Carburetor insert 8.5 (see illustration)
	17.09	Needle valve is stamped either "150" or "200"
	17.10	Start jet is stamped with the digits "60"
	17.11	Settings of the carburetor adjustment screws are free.
17.12	A minimum required size of main jet may be determined for each race event by a "Supplementary Regulation".	

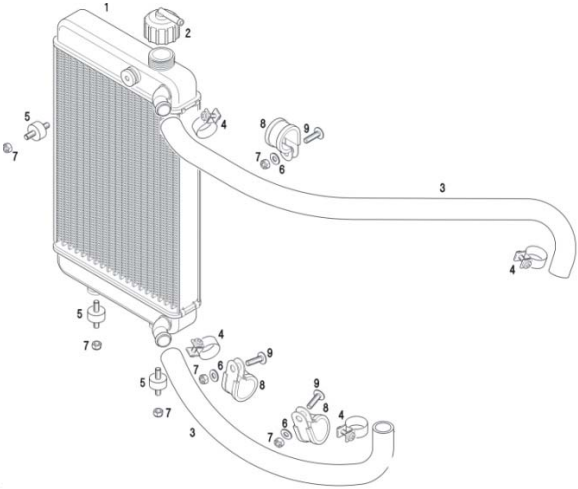

	17.13	<p>Optional carburetor plug screw (ROTAX part number 261030) is legal to be used.</p> 
Fuel pump	18.1	<p>Original MIKUNI diaphragm pump must be fitted by means of two original silent blocks to the chassis or the engine. Original MIKUNI diaphragm pump</p> 
	18.2	<p>Center line of fuel pump may not be higher than the center line of the carburetor.</p>
Fuel filter	19.1	<p>The 2 original fuel filter versions only (see attached pictures) are allowed to be fitted between the fuel tank and the fuel pump.</p>  <p>No additional parts except the fuel line, the fuel pump as well as the original fuel filter are legal to be mounted between fuel tank and carburetor.</p>

Radiator	<p>20.1</p> <p>20.2</p> <p>20.3</p> <p>20.4</p> <p>20.5</p> <p>20.6</p> <p>20.7</p> <p>20.8</p>	<p>Single aluminium radiator (see illustration below).</p> <p>Name "ROTAX" is stamped in the top/side of the radiator.</p> <p>Version 1: Cooling area: Height :284 mm, width:202 mm Version 2: Cooling area: Height :290 mm, width: 196 mm</p> <p>Version 1: Thickness of radiator = 32 mm Version 2: Thickness of radiator = 34 mm</p> <p>The radiator must be mounted on the left side side of the kart beside the seat.</p> <p>The highest point of the radiator with cap may not be higher than 400 mm above the main tube of the kart chassis.</p> <p>No additional non original cooling device is allowed For version 1 tape applied around the radiator is the only allowed air flow control. Tape may not be removed from the radiator during operation on the track. All other means of air flow control through the radiator are prohibited. For version 2 the original plastic flap is the only way to control the airflow. Removal of the original plastic flap as well as use of tape, like for the version 1 of the radiator, is an acceptable configuration.</p> <p>The removal of the thermostat from the cylinder head cover is an acceptable configuration.</p> <p>Version 1</p>  <p>Version 2</p> 
Radiator coolant	21.1	As glycol coolants are prohibited, plain water without any additives has to be used.

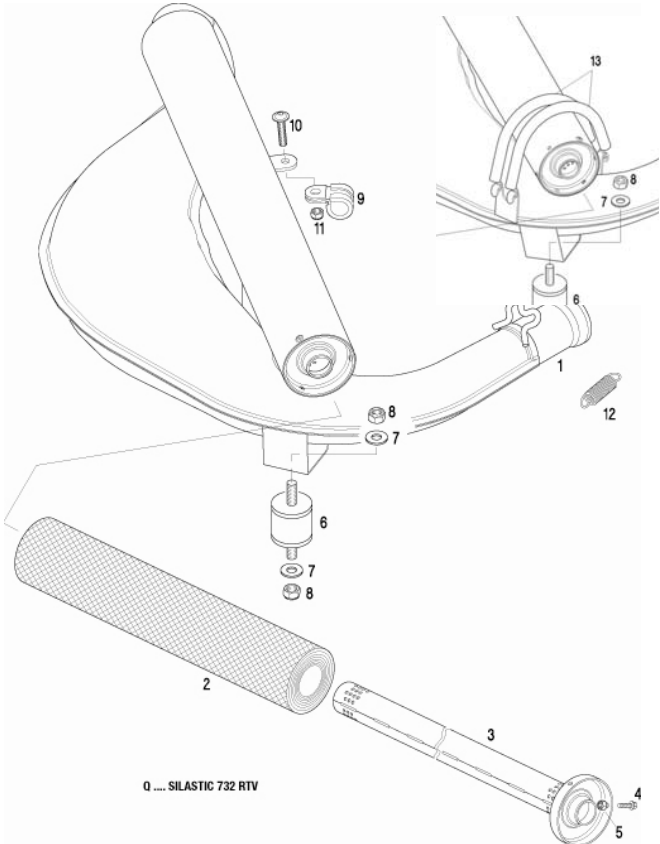
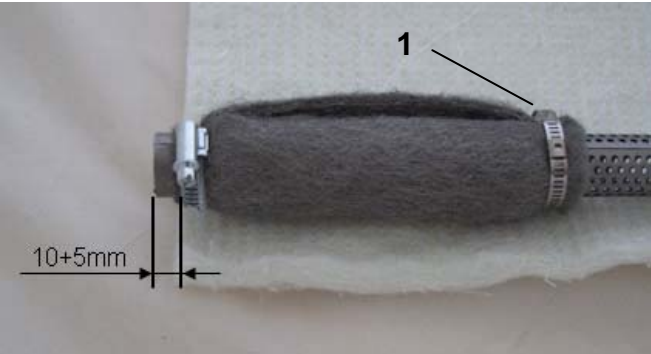
<p>Exhaust system</p>	<p>22.1 22.2 22.3</p>	<p>Must be as supplied by BRP-POWERTRAIN and cannot be modified except for the replacement of the silencer absorption material and the use of threaded fasteners in place of the rivets for securing the silencer end cap.</p> <p>Standard exhaust socket must be used.</p> <p>Exhaust pipe with after muffler (see illustration below). Both versions (version with welded on after muffler and version with after muffler fixed by 2 springs) are legal to be used.</p> 
	<p>22.4 22.5 22.6</p>	<p>Diameter of hole of end cap of (pos 3, illustration above): 19,6 mm +/-0,2 mm.</p> <p>Just one piece of original isolating mat is allowed to be used.</p> <p><u>Additional to the standard isolation mat a special steel isolation mat of the square dimension of 165 +10 mm is legal (not mandatory) to be assembled underneath the standard isolation mat as in following illustration. (Rotax part number of kit 297983).</u> <u>Clamp (1) as included in the kit is optional:</u></p> 

	22.7	The original exhaust system (tuned pipe and silencer) may not be modified, except for the addition of extra elements for further noise reduction.
	22.8	For measuring the exhaust gas temperature, it is allowed to weld on a socket of the exhaust in an area of 50 - 80 mm from the ball joint.
	22.9	The use of maximum 4 pieces of original BRP-POWERTRAIN exhaust springs to fix the exhaust to the cylinder is allowed. (no safety wire allowed in exhaust flange area).
Noise emissions	23.1	Noise isolating mat (see illustration exhaust system) has to be replaced by a original BRP-POWERTRAIN spare part, if the noise emission is exceeding 94 dB (A).
	23.2	Noise emission measuring procedure: The measuring place has to be at section of the track where the engine is operated under full load and at a rpm range of 11.000 to 12.000 rpm. The microphone has to be installed 1 meter above the level of the track in a rectangular angle to the track. The distance between the microphone and the kart on the ideal line on the track has to be 7,5 meters. The kart has to be operated under full load at the ideal line on the track.