



ROTAX MOJO MAX Challenge
Technical Regulations 2012
Appendix for 125 Mini MAX and 125 Micro MAX
 Version 23.01.2012

For the engine configuration 125 Mini MAX, everything that is not specified below, latest Technical regulation 2011 for engine configuration 125 Junior MAX is valid. It is the responsibility of the competitor to check his equipment (all components outside the engine seal and mentioned below), to assure that his equipment is in line with the technical specification below!

| | | |
|------------|-----|--|
| Squish gap | 1.1 | 125 Mini MAX 1,20 mm - 1,80 mm |
| | | <p>Authorized distributors organizing a national MAX Challenge for for the category 125 Mini MAX may determine a more restrictive squish gap within this tolerance.</p> <p>The squish gap must be measured with a certified slide gauge and by using a 2 mm tin wire. The crankshaft must be turned by hand slowly over TDC (top dead center) to squeeze the tin wire.</p> <p>Recommended 2mm tin wire : part no. 580 130</p> <p>The squish gap must be measured on the left and right side in the direction of the piston pin.</p> <p>The average value of the two measurements counts.</p> |

9.6 Technical Specification (outside the engine seal) for ROTAX kart engine 125 Mini MAX (10 kW)

For the engine configuration 125 Mini MAX, everything that is not specified below, the Technical Specification of items 9.2 for engine configuration 125 Junior MAX is valid. It is the responsibility of the competitor to check his equipment (all components outside the engine seal and mentioned below), to assure that his equipment is in line with the technical specification below!

| | | |
|--------------------|-----------------------|--|
| Intake restrictor | <p>2.1</p> <p>2.2</p> | <p>Authorized distributors organizing a national MAX Challenge for the category 125 Mini MAX may determine which intake restrictor must be used.</p> <p>Version 1 The intake restrictor (ROTAX part no. 267 535) must be fitted between the carburettor flange and the carburettor. The intake restrictor must show an inner diameter of 19,0 mm +0,0/-0,2 mm. The intake restrictor must show a blue anodised surface.</p> <p>Version 2 The intake restrictor (ROTAX part no. 267 530) must be fitted into the carburettor flange. The intake restrictor must show an inner diameter of 19,0 mm +0,2/-0,2 mm. The intake restrictor must show 4 fins in the inlet bore.</p> |
| Exhaust restrictor | <p>3.1</p> <p>3.2</p> | <p>The exhaust restrictor (ROTAX part no. 273 972) must be used instead of the original exhaust socket (fitted to the cylinder).</p> <p>The exhaust restrictor must show an inner-diameter of 22,0 mm +0,2/-0,2 mm.</p> |
| Noise emissions | <p>4.1</p> <p>4.2</p> | <p>Noise isolating mat (see illustration exhaust system) has to be replaced by a original ROTAX spare part, if the noise emission is exceeding 90 dB (A).</p> <p>Noise emission measuring procedure: The measuring place has to be at section of the track where the engine is operated under full load and at a rpm range of 9.000 to 10.000 rpm.</p> |

**9.7 Technical Specification (within the engine seal) for ROTAX kart engine
125 Micro MAX (5 kW)**

For the engine configuration 125 Micro MAX, everything that is not specified below, the Technical Specification of items 9.1 for engine configuration 125 Junior MAX is valid.

| | | |
|------------|-----|--|
| Squish gap | 1.1 | <p>125 Micro MAX 2,40 mm - 2,70 mm</p> <p>Authorized distributors organizing a national MAX Challenge for for the category 125 Mirco MAX may determine a more restrictive squish gap within this tolerance.</p> |
| | 1.2 | <p>To achieve the defined squish gap, a spacer (ROTAX part no. 626 420, same shape as a cylinder base gasket) with a thickness of 1,25 mm plus the different required base gaskets must be used. The squish gap must be measured with a certified slide gauge and by using a 3 mm tin wire. The crankshaft must be turned by hand slowly over TDC (top dead center) to squeeze the tin wire.</p> <p>Recommended 3mm tin wire : part no. 580 132</p> <p>The squish gap must be measured on the left and right side in the direction of the piston pin.</p> <p>The average value of the two measurements counts.</p> |

9.8 Technical Specification (outside the engine seal) for ROTAX kart engine 125 Micro MAX (5 kW)

For the engine configuration 125 Micro MAX, everything that is not specified below, latest Technical regulation 2011 for engine configuration 125 Junior MAX is valid. It is the responsibility of the competitor to check his equipment (all components outside the engine seal and mentioned below), to assure that his equipment is in line with the technical specification below!

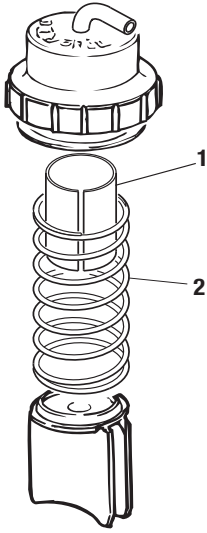
| | | |
|--------------------|----------------|---|
| Exhaust restrictor | 2.1 2.2 | The exhaust restrictor (ROTAX part no. 273 972) must be used instead of the original exhaust socket (fitted to the cylinder). The exhaust restrictor must show an inner-diameter of 22,0 mm +0,2/-0,2 mm. |
| Carburettor | 3.1 3.2 | The spacer (pos. 1, see illustration below, ROTAX part no. 251 730) must be fitted in the carburettor to limit the opening of the throttle. The length of the spacer has to be 38,0 mm +/-0,2 mm.  |

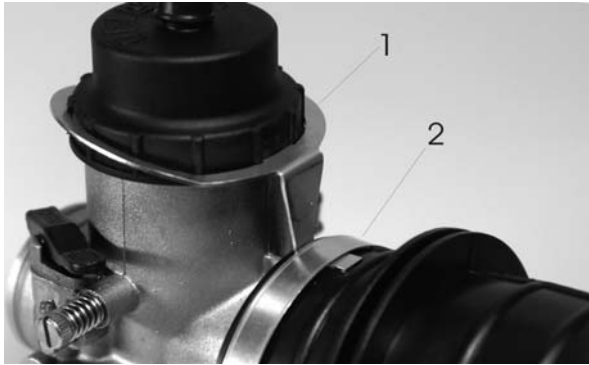
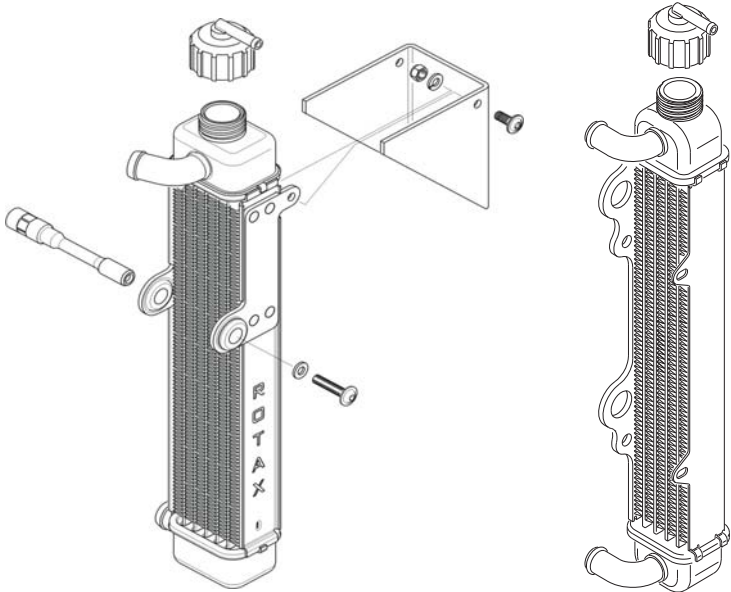
| | | |
|-----------------|----------------------------------|--|
| | <p>3.3</p> <p>3.4</p> <p>3.5</p> | <p>The position of the cap of the carburettor must be fixed by means of the fixation plate (pos. 1 see illustration below, ROTAX part no. 251 790, see attached picture). The cap of the carburettor has to be screwed completely on to the carburettor.</p>  <p>Only 1 rubber gasket is allowed to be used in the carburettor cap.</p> |
| <p>Radiator</p> | <p>4.1</p> <p>4.2</p> <p>4.3</p> | <p>A specific "Micro MAX" radiator (ROTAX part no. 295 924 or 295 923) must be used instead of the original radiator. Radiator must be mounted with all components similar to the illustration version 2 or 3 for the 125 max engine. (see item 18.8 of the technical regulations 2012). Cooling area: Height = 280 - 300 mm width = 58 -62 mm Thickness of radiator = 30 - 34 mm)</p>  |

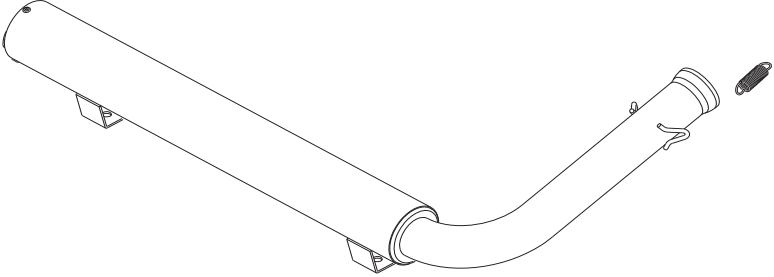
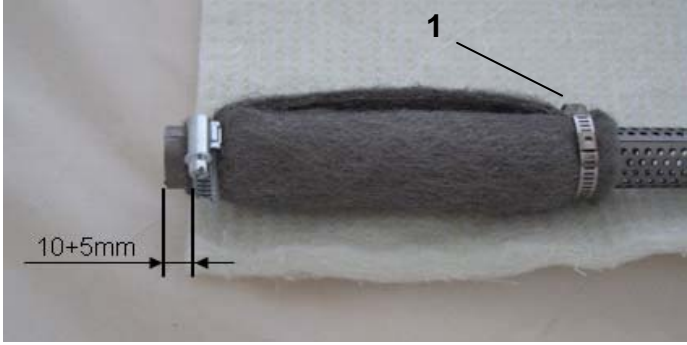
| | | |
|-----------------|----------------|--|
| Exhaust system | 5.1 5.2 | <p>The specific "Micro MAX" exhaust system must be used instead of the original exhaust system (see illustration below).</p> <p>The inner diameter of the 90° tube at the end of the silencer must be 15 mm +/- 0,30 mm.</p>  |
| | 5.3 | <p>Additional to the standard isolation mat a special steel isolation mat of the square dimension of 165 +10 mm must be assembled underneath the standard isolation mat as in following illustration. (Rotax part number 297983). Clamp (1) is optional.</p>  |
| Noise emissions | 6.1 6.2 | <p>Noise isolating mat (see illustration exhaust system) has to be replaced by a original ROTAX spare part, if the noise emission is exceeding 90 dB (A).</p> <p>Noise emission measuring procedure: The measuring place has to be at section of the track where the engine is operated under full load and at a rpm range of 8.000 to 9.000 rpm. The microphone has to be installed 1 meter above the level of the track in a rectangular angle to the track. The distance between the microphone and the kart on the ideal line on the track has to be 7,5 meters. The kart has to be operated under full load at the ideal line on the track.</p> |